

Specifications

AUDIO SECTION

Input Impedance (at 1kHz)	Phono (MC) : 100 ohm \pm 10%
	Phono (MM) : 47K ohm \pm 10%
	CD : 47K ohm \pm 10%
	Tape-1/2 : 47K ohm \pm 10%
	Video : 47K ohm \pm 10%
Sensitivity for Rated Power	Phono (MM) : 2.5mV \pm 10%
	Phono (MC) : 0.22mV \pm 10%
	CD : 150mV \pm 10%
	Tape-1/2 : 150mV \pm 10%
	Video : 150mV \pm 10%
Frequency Response (Video, CD, Tape)	20Hz~20kHz \pm 0.3dB
	5Hz~140kHz+1, -3dB
S/N Ratio [Output : Tape Out (A-Weighted)]	Phono (MM) (5mV Input Shorted) : 82dB
	Phono (MC) (500 μ V Input Shorted) : 66dB
[Output : Speaker Out at Rated Power (A-Weighted)]	CD (150mV Input Shorted) : 100dB
	Tape-1/2 (150mV Input Shorted) : 100dB
	Video (150mV Input Shorted) : 100dB
Cross Talk (10kHz)	60dB
Power Output (20Hz~20kHz) (T.H.D. 0.03%)	: 160W

VIDEO SECTION

Frequency Response (75 ohm Terminated)	10Hz~6MHz \pm 1dB
Video Input/Output (75 ohm Terminated)	1.0Vp-p \pm 5%

AM SECTION

Frequency Range	530~1,620kHz
IF Frequency	450kHz
Quieting Sensitivity (20dB)	600kHz : 800 μ V/m
	1,000kHz : 700 μ V/m
	1,400kHz : 700 μ V/m
S/N Ratio (100mV Input)	1,000kHz : 50dB
Selectivity (at S/N 20dB Input \pm 10kHz)	1,000kHz : 35dB
IF Rejection Ratio	600kHz : 50dB
Image Rejection Ratio	1,400kHz : 40dB
Distortion (T.H.D. at 100mV Input 30% mod)	1,000kHz : 0.5%

FM SECTION

Frequency Range	87.9~107.9MHz
Usable Sensitivity	98.1MHz : 13.2dBf
Quieting Sensitivity (50dB)	98.1MHz : 15.2dBf
S/N Ratio (65dBf Input)	98.1MHz : 79dB
Frequency Response (65dBf Input, 20Hz~15kHz)	98.1MHz : +0.5, -1.0dB
Distortion (65dBf Input)	98.1MHz : 0.08%
Capture Ratio	98.1MHz : 1.8dB
Alternate Channel Selectivity	98.1MHz (Wide) : 50dB
	98.1MHz (Narrow) : 75dB
Image Response Ratio	106.1MHz : 80dB
IF Response Ratio	90.1MHz : 100dB

GENERAL

Power Consumption	160W
Power Supply	120V, 60Hz
Semi-Conductors	30 IC's, 118 Transistors, 118 Diodes, 16 Zener Diodes
Dimensions	438 (W) \times 139 (H) \times 424 (D) mm
Weight	15.2kg

NOTE : Due to continuing product improvement, specifications and designs are subject to change without notice.

Parts Locations and Disassembly Instructions

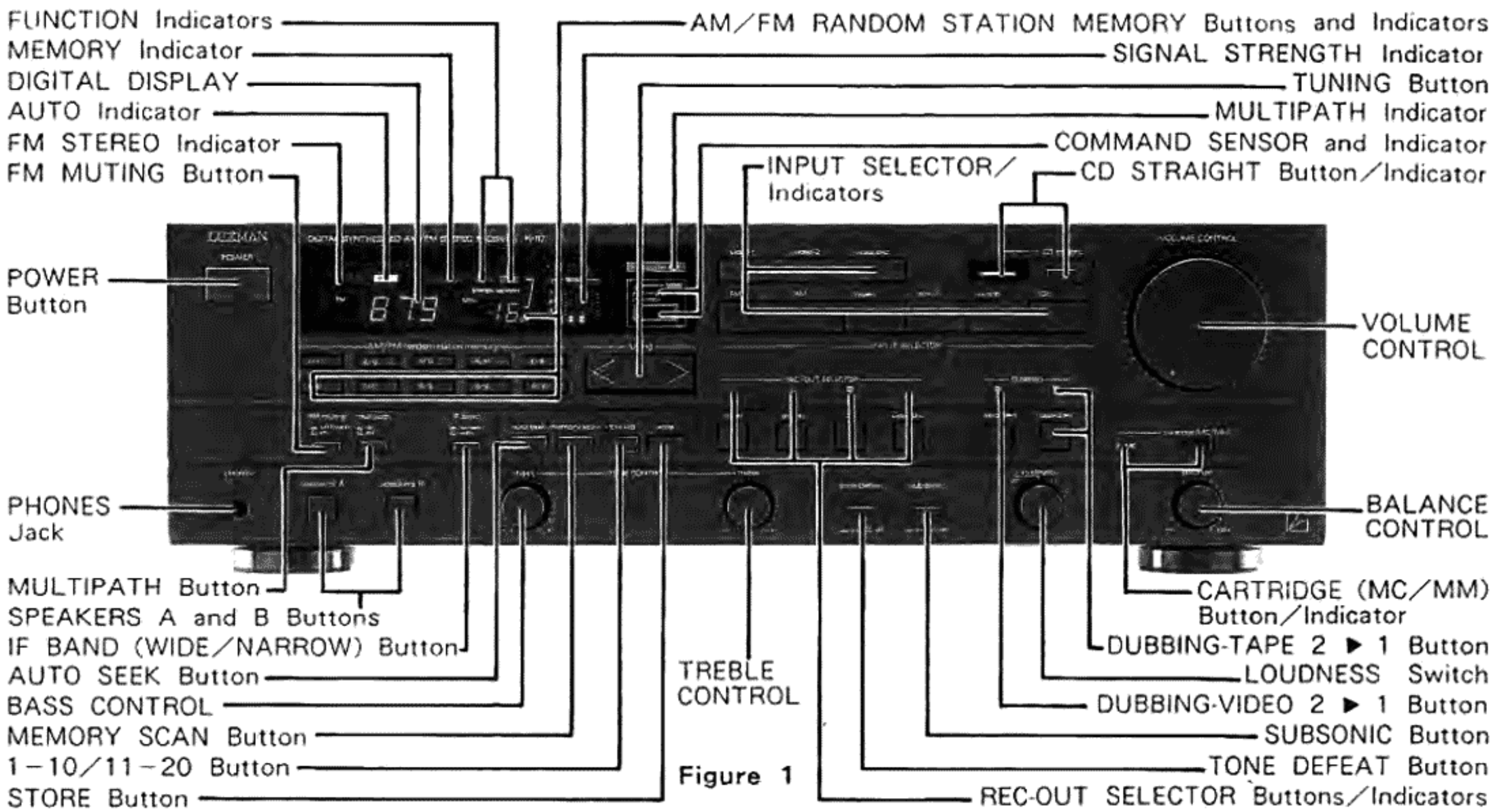

Figure 1

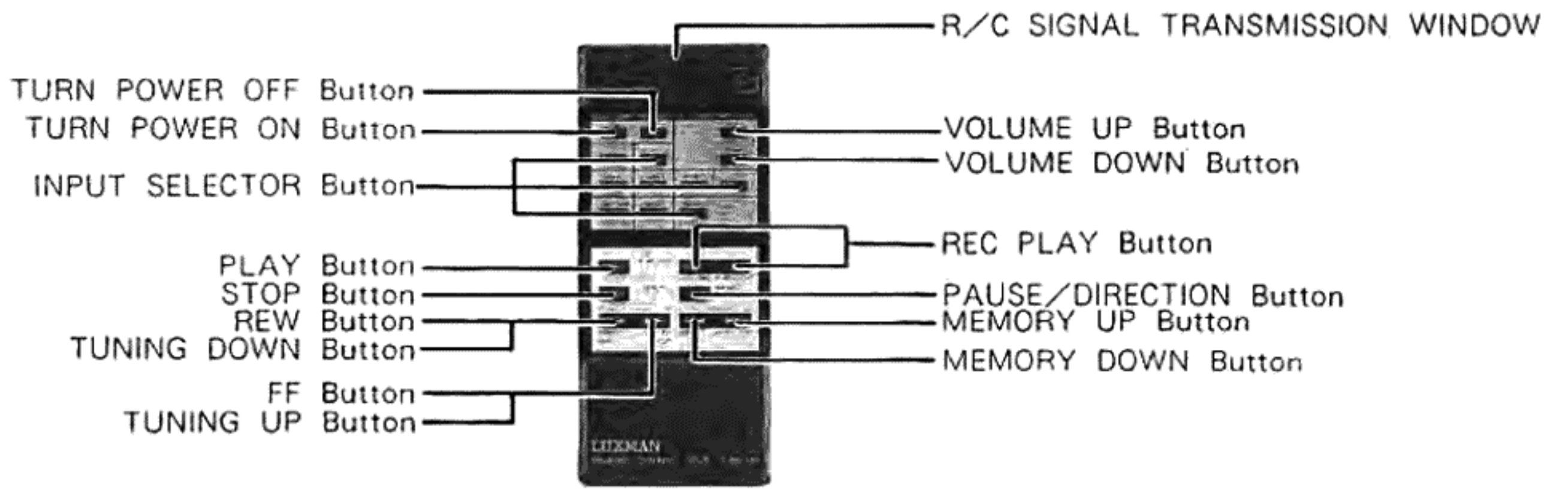

Figure 2

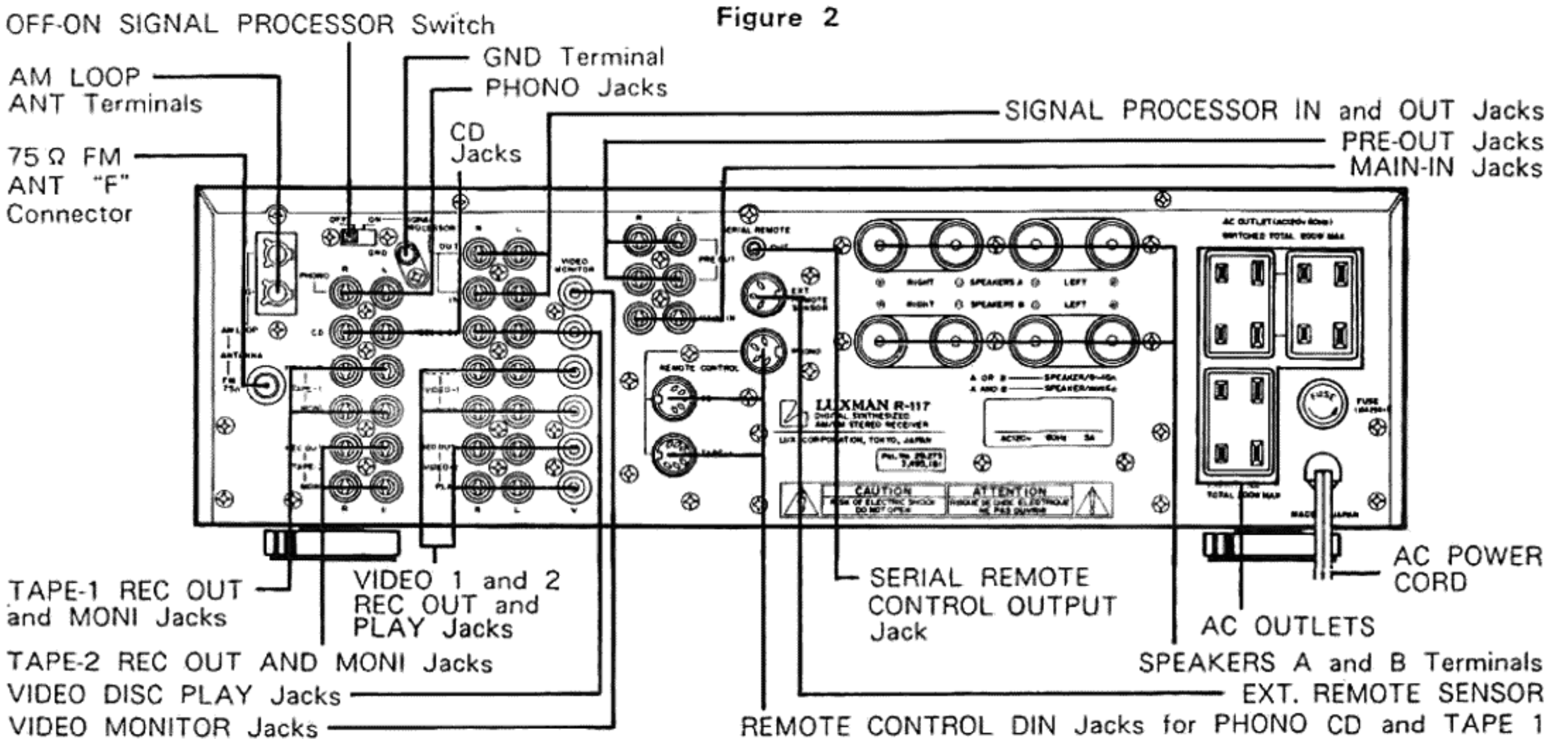

Figure 3

Adjustment Procedures

1. Audio Section

(1) Connection

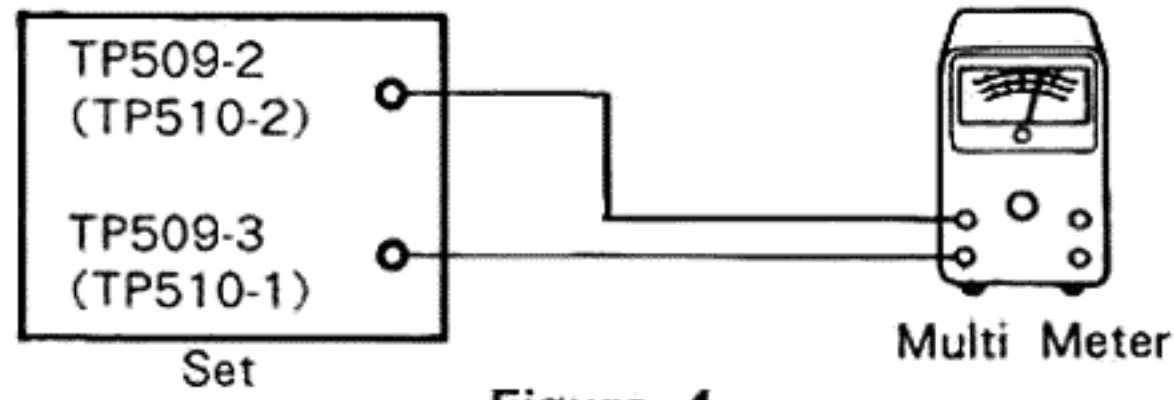

Figure 4

(2) Control Setting

- Volume Control Minimum
- Speaker Switch OFF

(3) Procedures

Step	Description	Adjust Points	Test Points	Connection	Remarks
	Idling Adjustment	SVR501 (L)	TP509-2 -3 L	Figure 4	Power switch on and wait 5 minutes for warming-up. Adjust to $5 \pm 2\text{mV}$.
		SVR502 (R)	TP510-1 -2 R		

2. Tuner Section

AM

(1) Connection

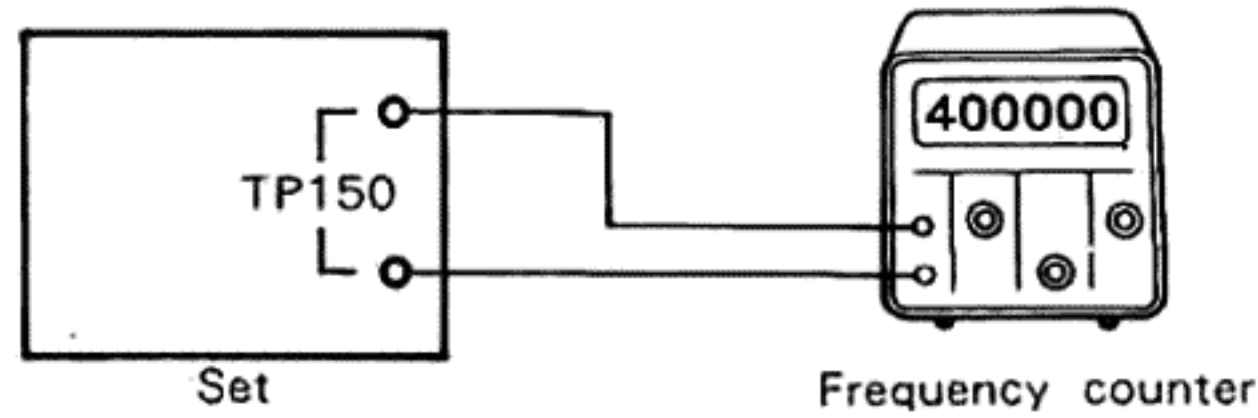

Figure 5

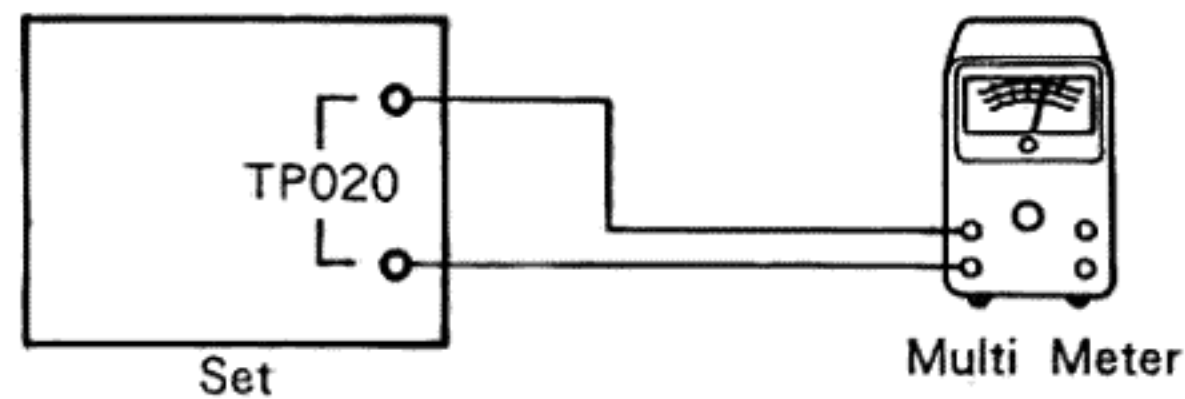

Figure 6

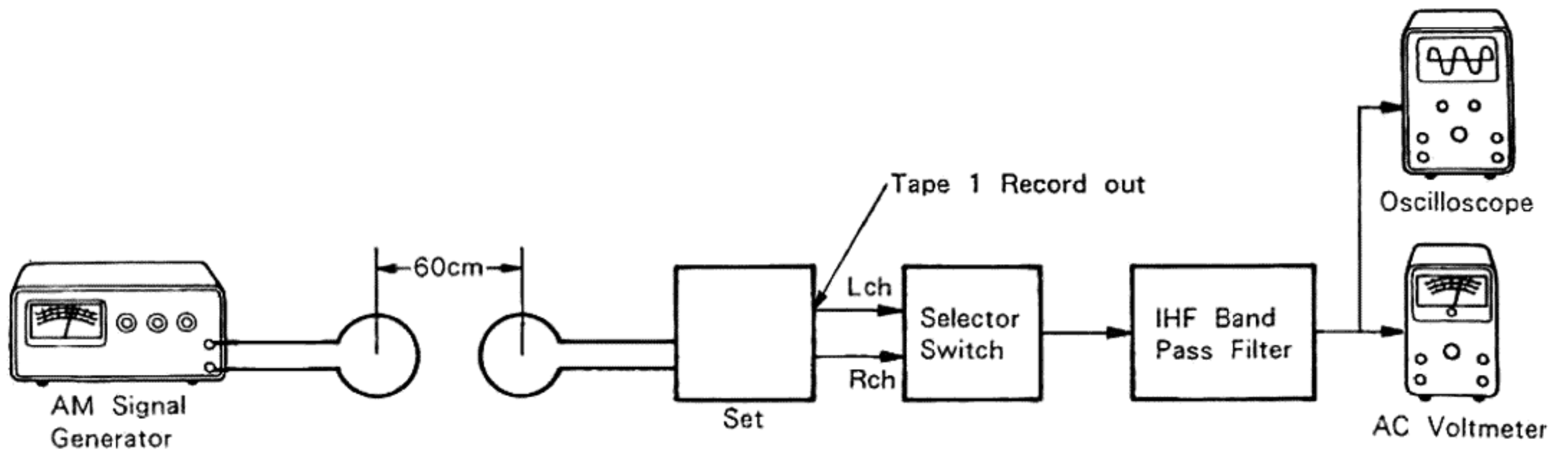

Figure 7

(2) Control Settings

Input Selector AM
 Rec Out Selector Tuner
 Muting OFF

(3) Procedures

Step	Description	Signal Generator	Dial Control	Adjust Points	Test Points	Connection	Remarks
1	PLL Frequency Adjustment	—	—	TC151	TP150	Figure 5	Adjust to $400 \pm 0.002\text{kHz}$.
2	Tracking Adjustment	—	(1) 530kHz	L005	TP020	Figure 6	Adjust to $1.9 \pm 0.05\text{V}$.
			(2) 1,620kHz	TC052			Adjust to $22 \pm 0.5\text{V}$.
3	IF Adjustment	450kHz MOD : 400Hz 30%	1,000kHz	L004	Tape 1 Rec out	Figure 7	To maximum output.
4	Sensitivity Adjustment	600kHz	600kHz	L003	Tape 1 Rec out	Figure 7	To maximum output.
		1,400kHz	1,400kHz	TC051			To maximum output.
5	Muting Level Adjustment	1,000kHz $60\text{dB } \mu\text{V/m}$	1,000kHz	SVR151	Tape 1 Rec out	Figure 7	Muting Switch ON. Rotate SVR151 fully counterclockwise. Then, return it clockwise with a waveform appears.
6	Signal Strength Meter Level Adjustment	1,000kHz $70\text{dB } \mu\text{V/m}$	1,000kHz	SVR152			Adjust SVR152 so that segment 4 of the signal strength meter light up.

FM

(1) Connection

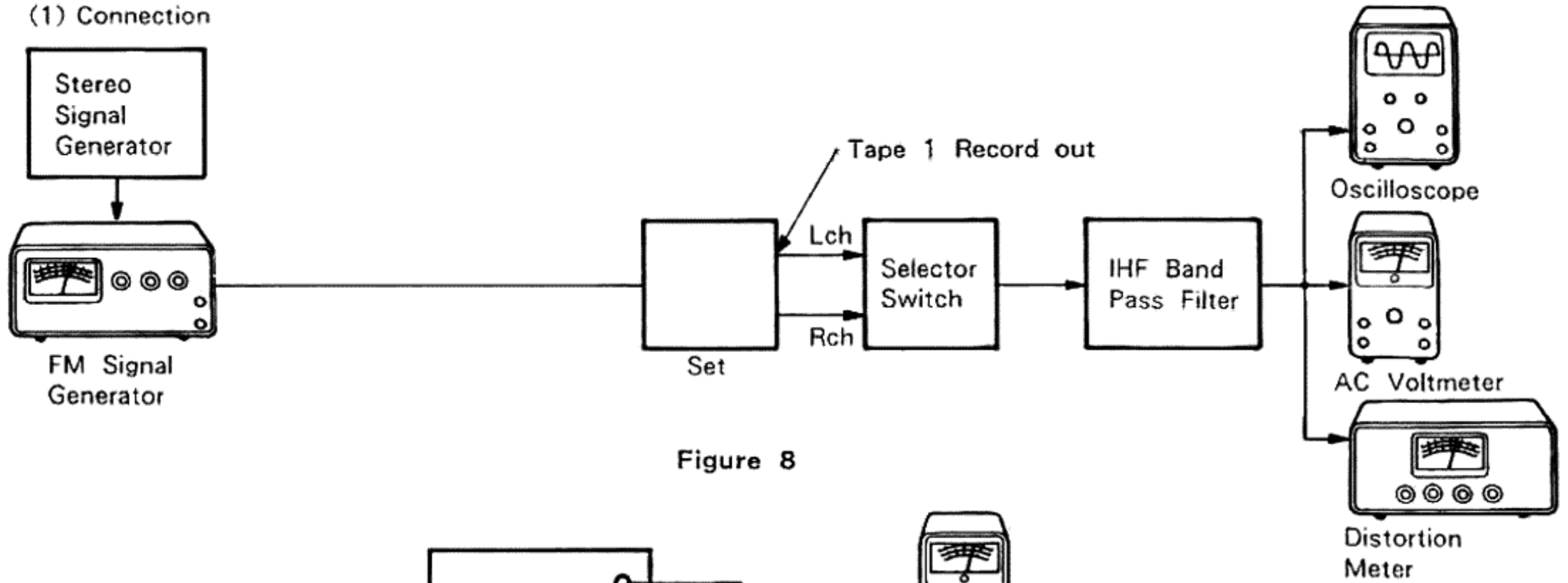

Figure 8

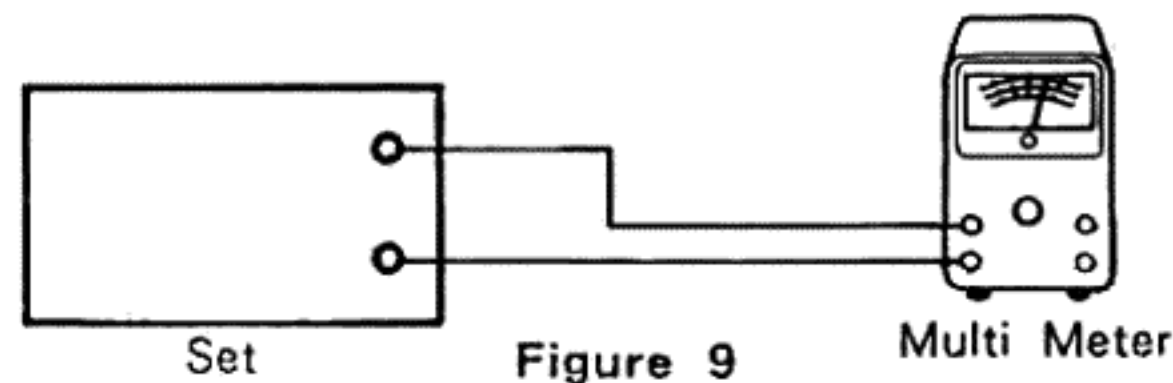

Figure 9

(2) Control Setting

Input Selector FM
 Rec out Selector Tuner
 Muting OFF
 IF Band Wide

Step	Description	Signal Generator	Dial Control	Adjust Points	Test Points	Connection	Remarks
1	Center Voltage and THD Adjustment	98.1MHz 65dBf MOD : 1kHz 100% MONO	98.1MHz	L001 PRI L001 SEC	TP010 Tape 1 Rec out	Figure 9 Figure 8	1. Adjust L001 PRI to $0 \pm 3mV$. 2. Adjust L001 SEC to minimum distortion. Repeat Step 1, 2.
2	IF Adjustment	98.1MHz 65dBf MONO	98.1MHz	Front-end IFT	Tape Rec out	Figure 8	Adjust Front-end IFT to minimum distortion.
3	Muting Level Adjustment	98.1MHz 31.2dBf MONO	98.1MHz	SVR001	Tape 1 Rec out	Figure 8	Muting Switch ON. Rotate SVR001 fully counterclockwise. Then, return it clockwise with a waveform appears.
4	Signal Strength Meter Level Adjustment	98.1MHz 23.3dBf MONO	98.1MHz	SVR171	-		Adjust SVR171 so that Segment 1 of the signal strength meter light up.

Step	Description	Signal Generator	Dial Control	Adjust Points	Test Points	Connection	Remarks
5	Separation Adjustment (WIDE)	(1) 98.1MHz 65dBf MOD : 1kHz L only	98.1MHz	SVR104 SVR103	Tape 1 Rec out	Figure 8	Adjust SVR104 to minimum at R channel output.
		(2) R only					Adjust SVR103 to minimum at L channel output.
		Repeat Step (1), (2).					
6	Separation Adjustment (NARROW)	98.1MHz 65dBf MOD : 1kHz L (R) only	98.1MHz	SVR102	Tape 1 Rec out	Figure 8	IF Band Switch NARROW. Adjust SVR102 to minimum at R (L) channel out put.
7	Auto Hi-Blend Level Adjustment	98.1MHz 35dBf MOD : 10kHz L (R) only	98.1MHz	SVR153	Tape 1 Rec out	Figure 8	Rotate SVR153 fully counterclockwise Then, return it clockwise until a waveform disappears.

Adjustment Locations

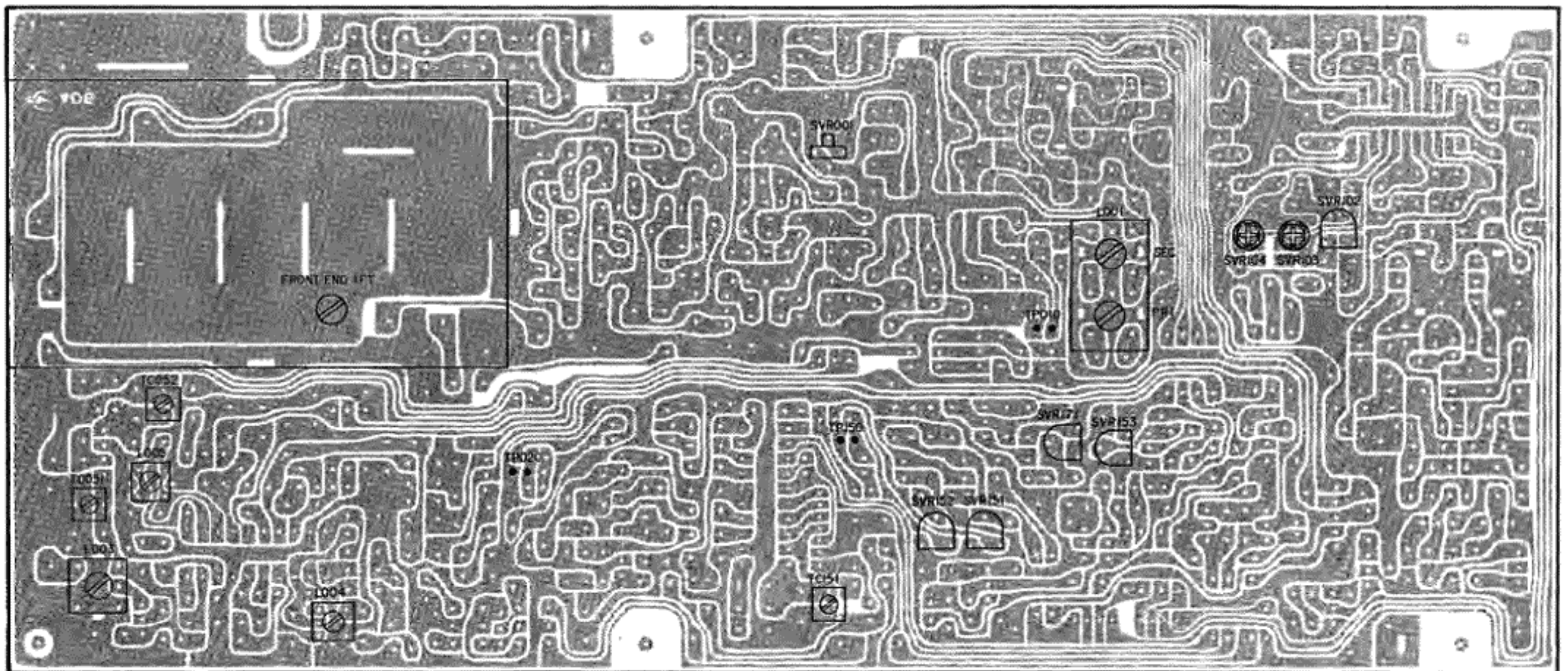

Tuner P. C. Board

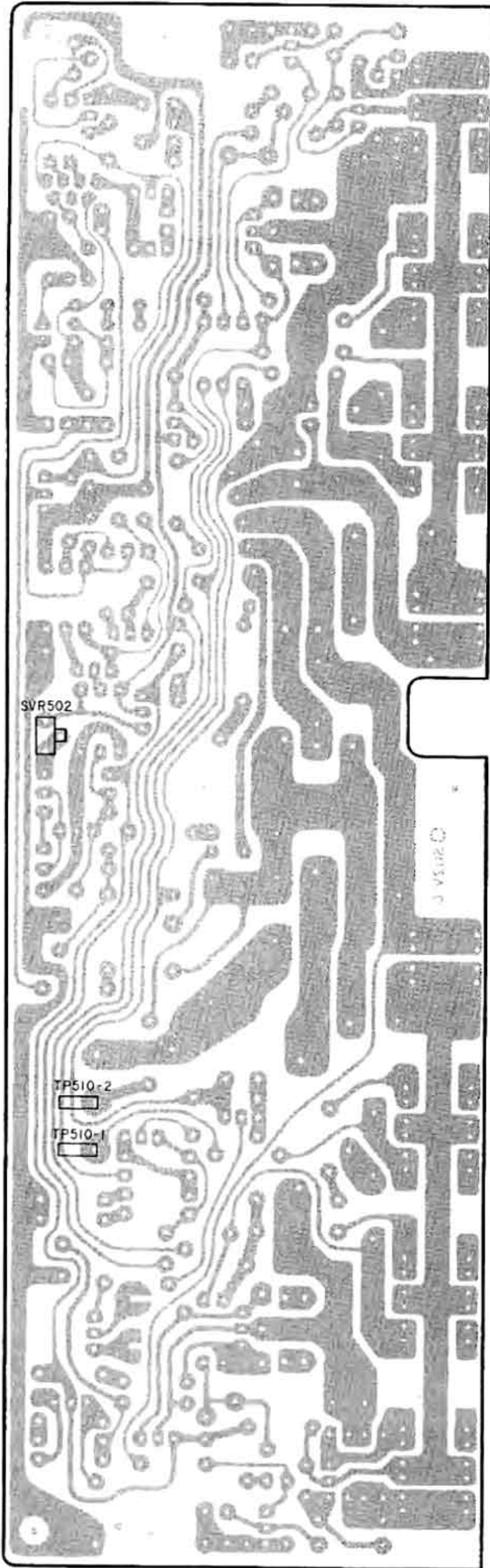

Main P. C. Board (R)

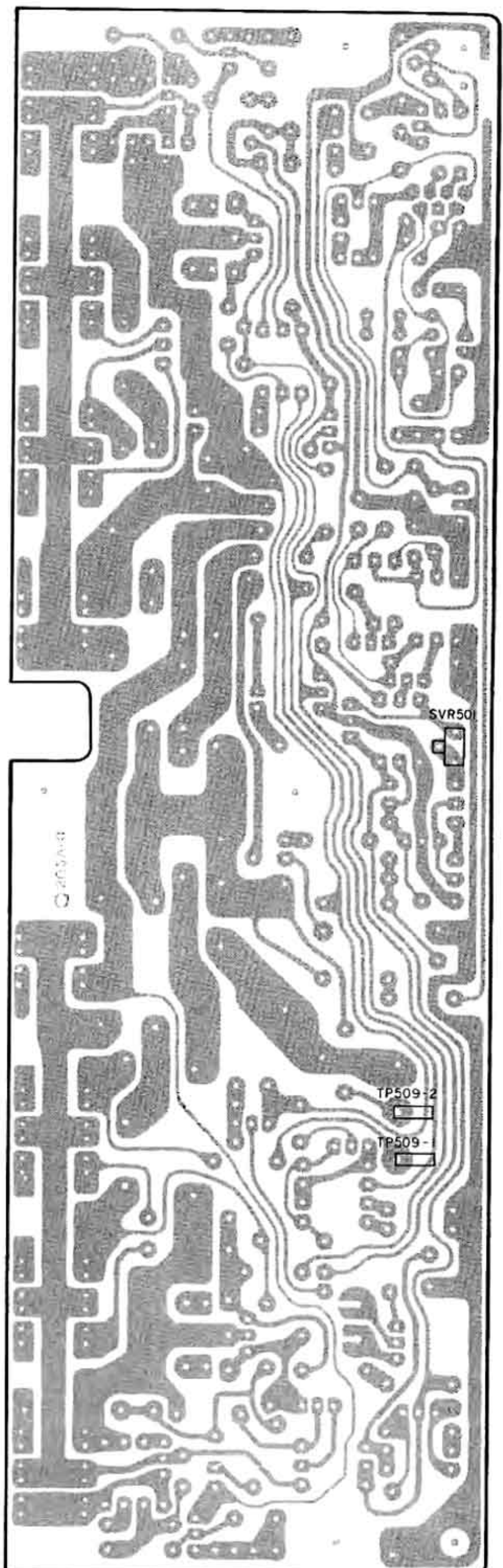

Main P. C. Board (L)

Block Diagram

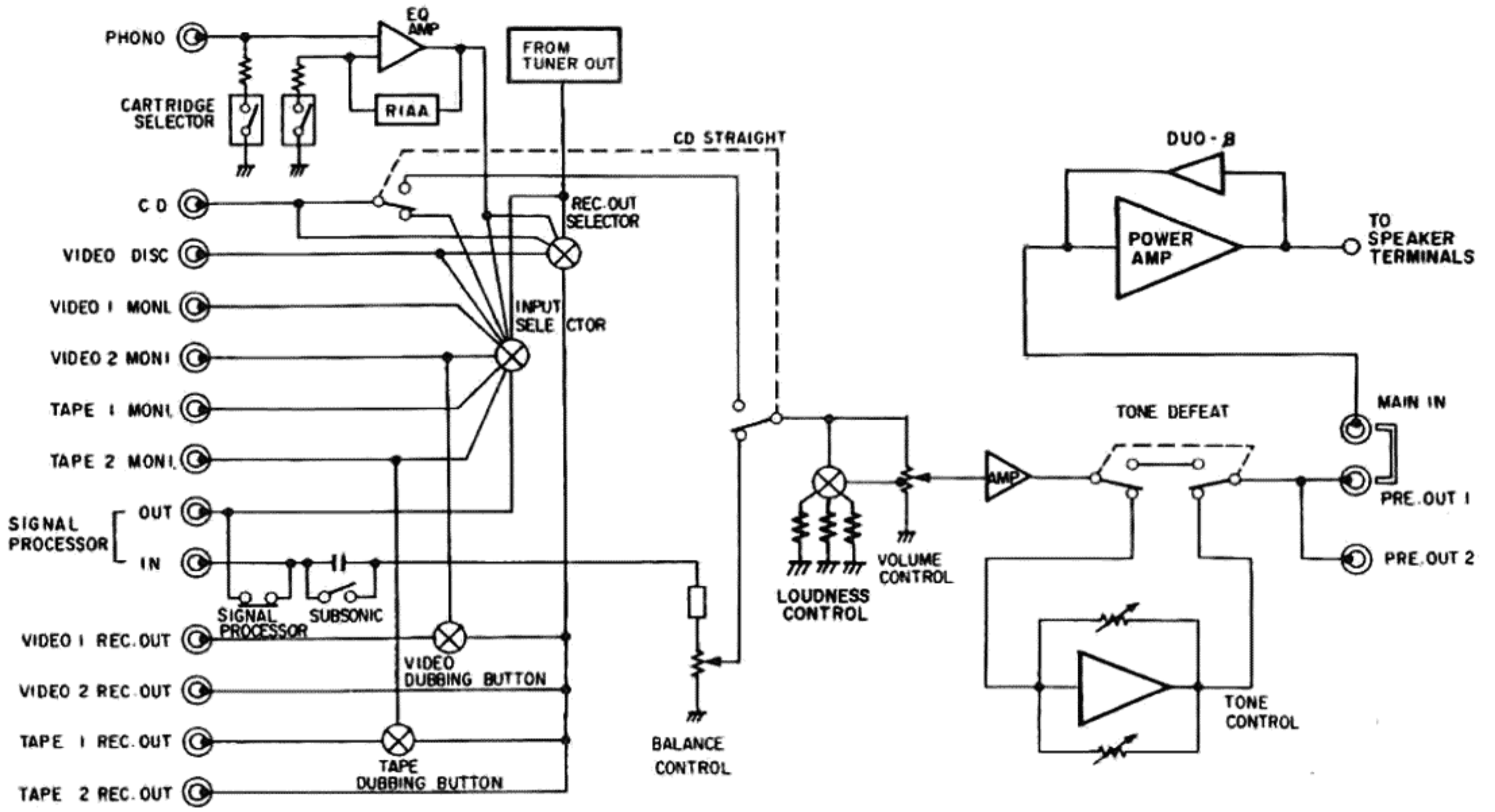

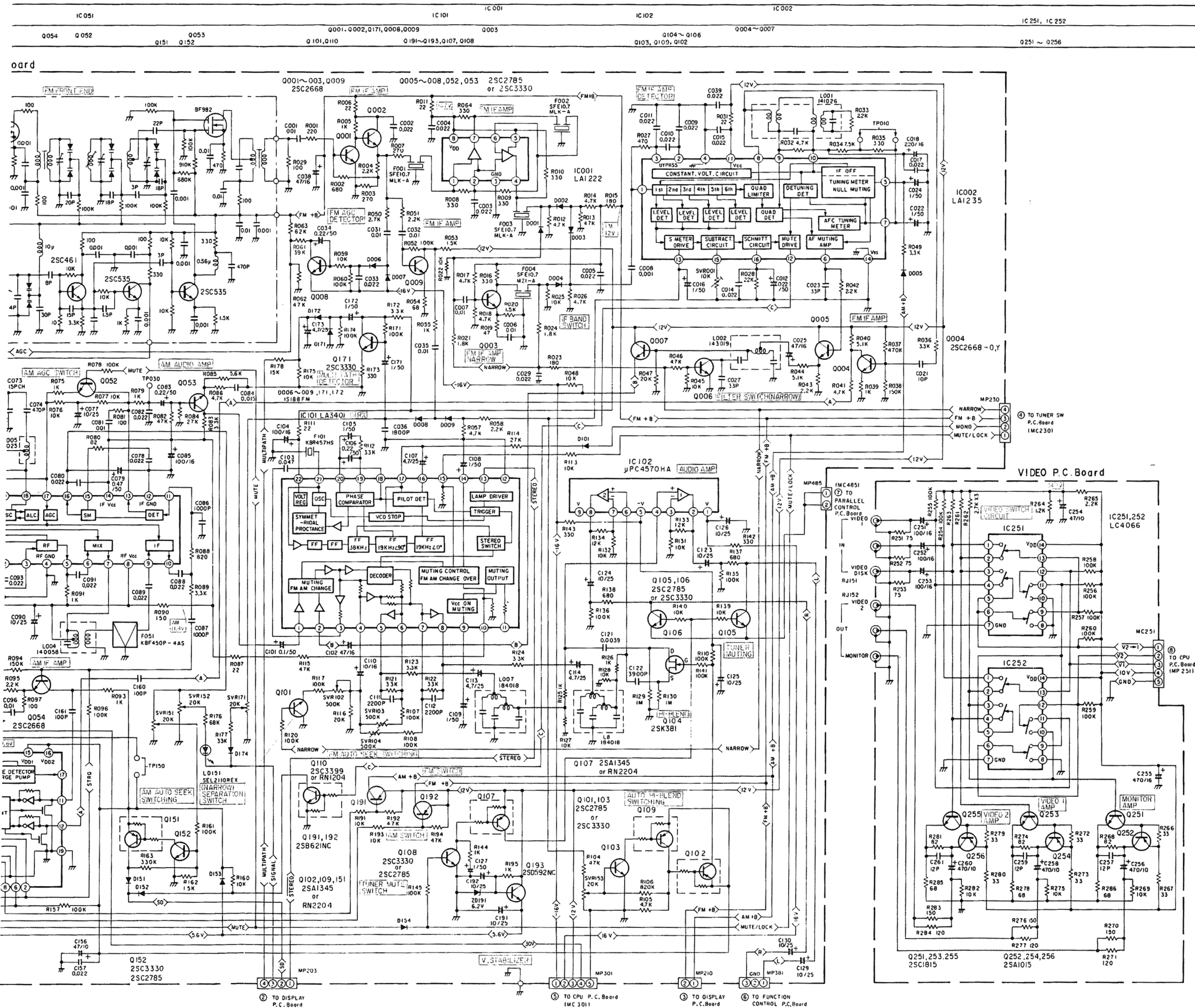

IC 0 0 1

1	1.4V
2	1.4V
3	3V
4	11V
5	12V
6	1.4V
7	11V
8	12V

IC 2 5 1

1	3.3V	8	0V
2	3.3V	9	10.6V
3	3.3V	10	0V
4	0V	11	10.6V
5	10.6V	12	0V
6	10.6V	13	10.6V
7	0V	14	10.7V

IC 0 0 2

1	2.8V	9	6.3V
2	2.8V	10	6.3V
3	2.8V	11	11.6V
4	0V	12	6.3V
5	0.8V	13	1V
6	6.4V	14	0V
7	5.5V	15	0.5V
8	6.2V	16	0.5V

IC 2 5 2

1	0V	8	0V
2	3.3V	9	10.6V
3	3.3V	10	3.3V
4	3.3V	11	0V
5	10.6V	12	0V
6	0V	13	0V
7	0V	14	10.7V

IC 0 5 1

1	5.6V	11	0.7V
2	2.1V	12	0V
3	2.7V	13	2.1V
4	0V	14	11.5V
5	0V	15	1.5V
6	2	16	0V
7	9.6V	17	2V
8	9.6V	18	5.6V
9	2.7V	19	5.6V
10	7.5V	20	3V

	E	C	B
Q001	0V	7.8V	0.7V
Q002	7V	11.8V	7.8V
Q003	4.7V	9.9V	5.4V
Q004	1.1V	6.4V	1.8V
Q005	5.5V	12V	8.1V
Q006	0V	0V	0.6V/0V
Q007	-0.7V	12V	0V
Q008	-12V	5.1V	-12V
Q009	0.3V	4.8V	1V
Q052	2V	2V	0V
Q053	3.5V	8.7V	4.1V
Q054	0V	4.8V	0V
Q101	0V	0V	0.6V/0V
Q102	4.9V	-14V	4.8V
Q103	0V	0V	0.6V
Q106	0V	0V	0V
Q107	12V	0V	12V
Q108	0V	12V	0V
Q109	4.9V	4.8V	0V
Q110	0V	4.9V	0V
Q151	4.9V	4.9V	0V
Q152	0V	0V	0.6V
Q171	0.9V	2.7V	1.6V
Q191	12V	12V/0V	AM 11.4V
Q192	12V	12V/0V	FM 12V
Q193	5.6V	13V	6.2V

IC 1 0 2

1	14.2V
2	0V
3	0V
4	4V
5	-14.2V
6	0V
7	0V
8	0V

	D	G	S
Q051	7.5V	0V	0.4V
Q104	0V	-14V	0V

IC 1 5 1

1	1.6V	11	0.1V
2	0V	12	0.1V
3	0V	13	0.1V
4	0V	14	2.8V
5	0V	15	4.0V
6	4.8V	16	4.3V
7	0V	17	0V
8	12V	18	2.8V
9	0.2V	19	0V
10	0V	20	1.6V

IC 1 5 2

1	29.7V
2	1W 2.5V - 25V
3	AM 1.3V
4	2.8V
5	2.8V
6	2.8V
7	2.8V
8	3.2V
9	3.8V
10	0V
11	3.3V

IC 1 0 1

1	3.2V	12	0V
2	3.2V	13	4.3V
3	3.2V	14	4.3V
4	3.2V	15	0V
5	3.2V	16	2.8V
6	3.2V	17	2.8V
7	3.2V	18	2.8V
8	3.2V	19	2.8V
9	3.8V	20	2.8V
10	0V	21	3.4V
11	3.3V	22	11.6V

- NOTES
- UNLESS OTHERWISE NOTICED ALL DIODES ARE 1N41 OR 1N41A.
 - All resistors are 1/4 watt or 1/6 watt ±5% unless otherwise noted. Resistor values are in ohms. (K=1000 ohms. M=1000K ohms)
 - All capacitor values are in microfarads. (P=picofarads)
 - Each DC voltage shows the nominal values in volts no input signal.
 - When replacing varactor diodes VD51 and VD52 always use a diode with the same rank.

Schematic Diagram (2/4)

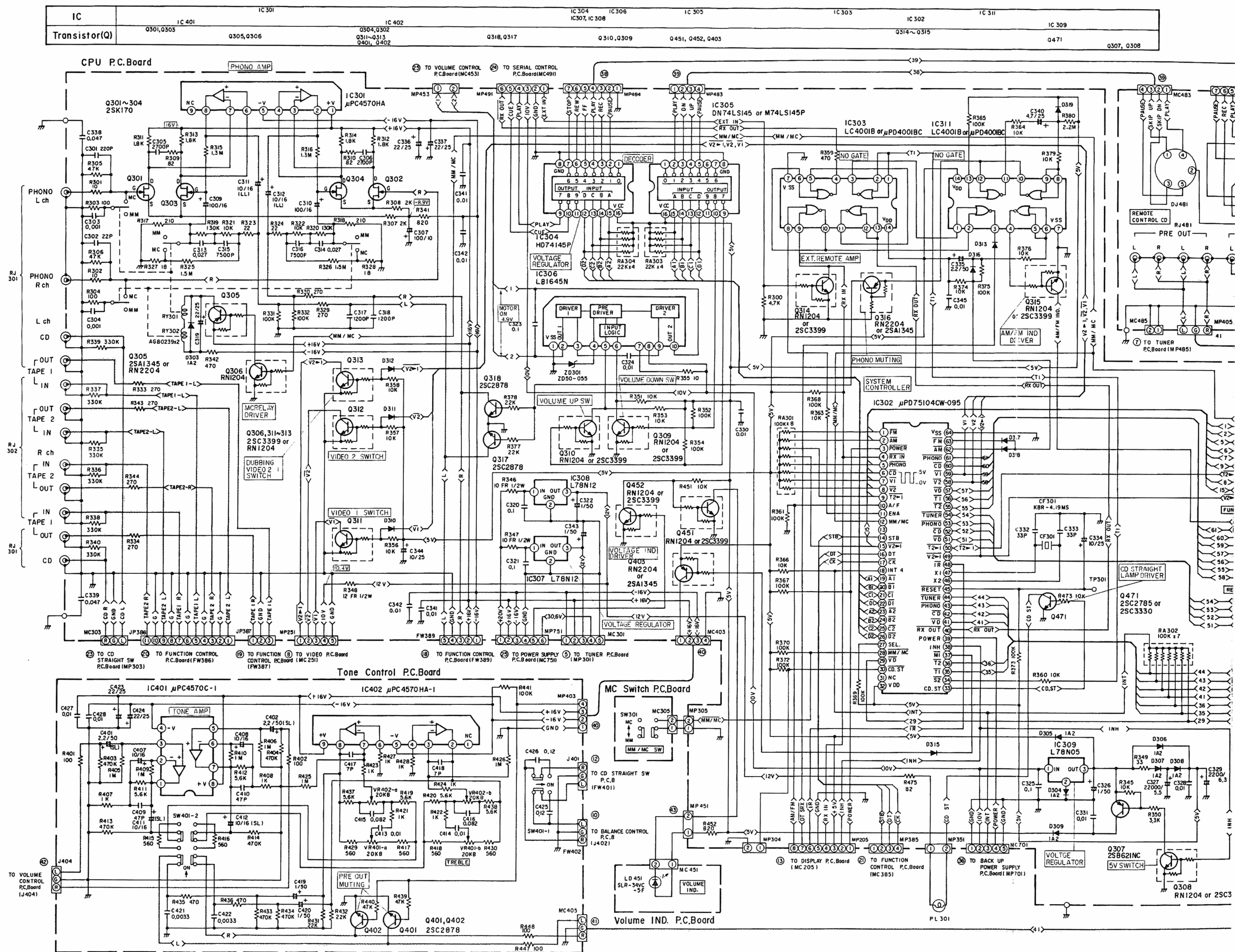

Schematic Diagram (3/4)

IC	IC 202 IC 204	IC 201	IC 203	Q202 Q201	Q235	IC 381, IC 382
Transistor(Q)						

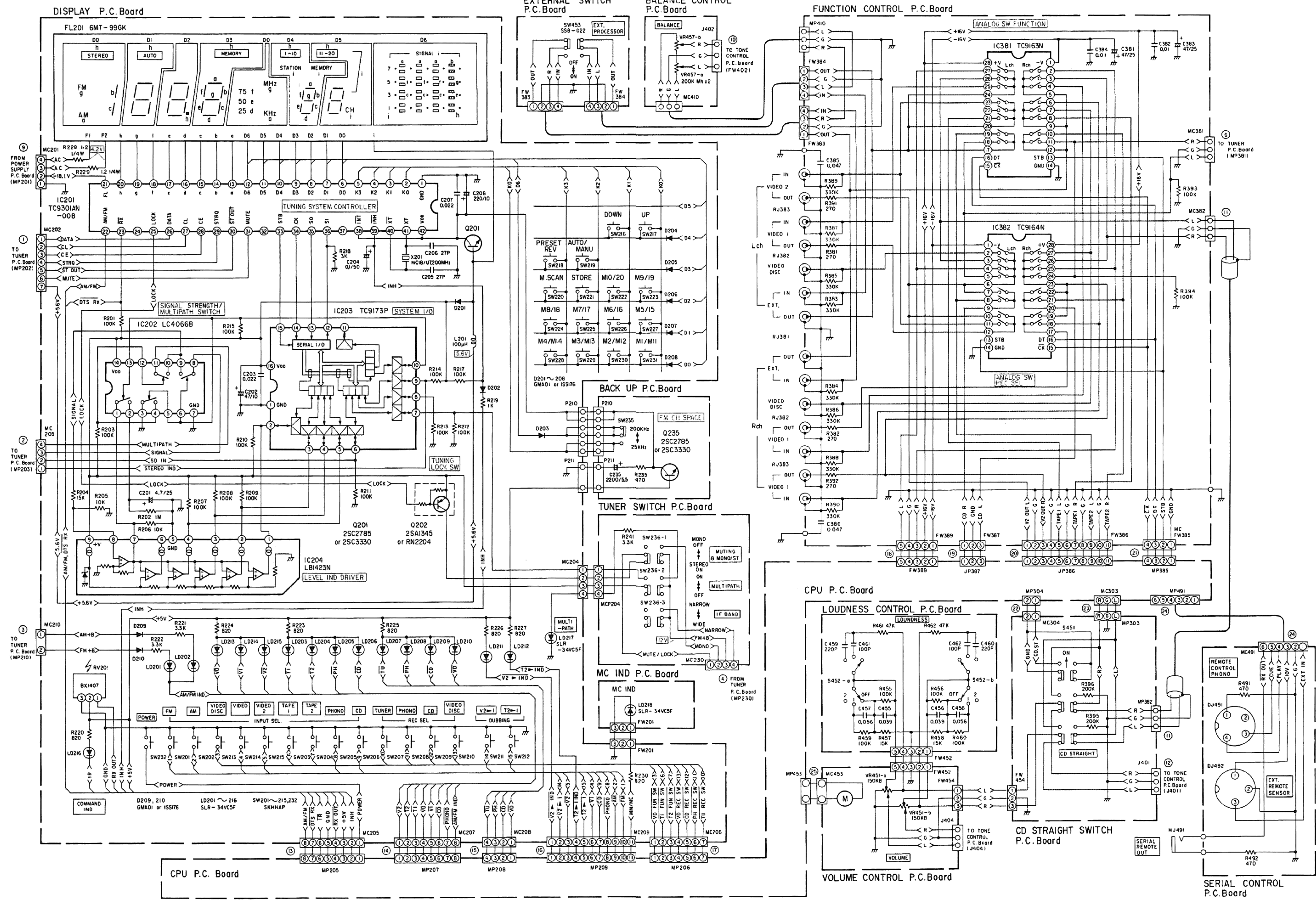

- Notes:** (on SW235 FM CH. Space Switch)
- Set SW235 to the 25kHz position to change the frequency increment to 25kHz from 200kHz in the Manual tuning.
 - Set SW235 to the 200kHz position to change the increment to 200kHz from 25kHz. In this case, ensure the followings.
 - When the switch is set to the 25kHz position, call every preset stations by pressing the preset station keys.
 - If the lowest frequency of receiving frequency is 25kHz, 50kHz, or 75kHz, change the lowest frequency to other frequency other than above by operating the tuning key and store the frequency onto the preset station which was called.
 - After performing the same procedures for all other preset stations, set SW235 to the 200kHz position.
 - If the lowest frequency displayed is 25kHz, 50kHz or 75kHz, change to the auto tuning mode and press the tuning. Then the frequency increment step changes to 200kHz.

IC 201

1	0V	15	25	0V	
2	0V	16	30	4.7V	
3	0V	17	31	0V	
4	0V	18	32	0V	
5	0V	19	33	0V	
6	0V	20	34	0V	
7	0V	21	-18.1V	35	0V
8	0V	22	4.7V/0V	36	0V
9	0V	23	4.7V	37	0V
10	0V	24	38	4.7V	
11	0V	25	0V	39	4.7V
12	0V	26	0V	40	1.7V
13	0V	27	0V	41	2.7V
14	0V	28	0V	42	4.7V

IC 203

1	0V	5	4.8V/0V
2	4.8V/0V	10	4.8V
3	4.8V/0V	11	0V
4	4.8V/0V	12	0V
5	4.8V/0V	13	0V
6	4.8V/0V	14	0V
7	4.8V/0V	15	0V
8	0V	16	4.8V

IC 202

1	0V	8	0V
2	0V	9	0V
3	0V	10	0V
4	0V	11	0V
5	4.8V	12	0V
6	4.8V	13	4.8V
7	0V	14	4.8V

IC 204

1	4.8V/0V
2	4.8V/0V
3	4.8V/0V
4	4.8V/0V
5	0V
6	0V
7	0V
8	0V
9	4.8V

IC 381

1	-18V	15	5V
2	0V	16	0V
3	0V	17	0V
4	0V	18	0V
5	0V	19	0V
6	0V	20	0V
7	0V	21	0V
8	0V	22	0V
9	0V	23	0V
10	0V	24	0V
11	0V	25	0V
12	0V	26	0V
13	0V	27	0V
14	0V	28	18V

IC 382

1	-18V	15	5V
2	0V	16	0V
3	0V	17	0V
4	0V	18	0V
5	0V	19	0V
6	0V	20	0V
7	0V	21	0V
8	0V	22	0V
9	0V	23	0V
10	0V	24	0V
11	0V	25	0V
12	0V	26	0V
13	0V	27	0V
14	0V	28	18V

E	C	B
Q201	4.8V	4.7V 5.5V
Q202	4.8V	0V 4.7V
Q235	4.8V	4.7V 5V

- NOTES:**
- UNLESS OTHERWISE NOTICED ALL DIODES ARE GM401 OR 1SS176.
 - All resistors are 1/4 watt or 1/8 watt. ±5% unless otherwise.
 - Resistor values are in ohms; (K=1000 ohms; M=1000K ohms)
 - All capacitor values are in microfarads. (P=picofarads)
 - Each DC voltage shows the nominal values in volts no input signal.

Schematic Diagram (4/4)

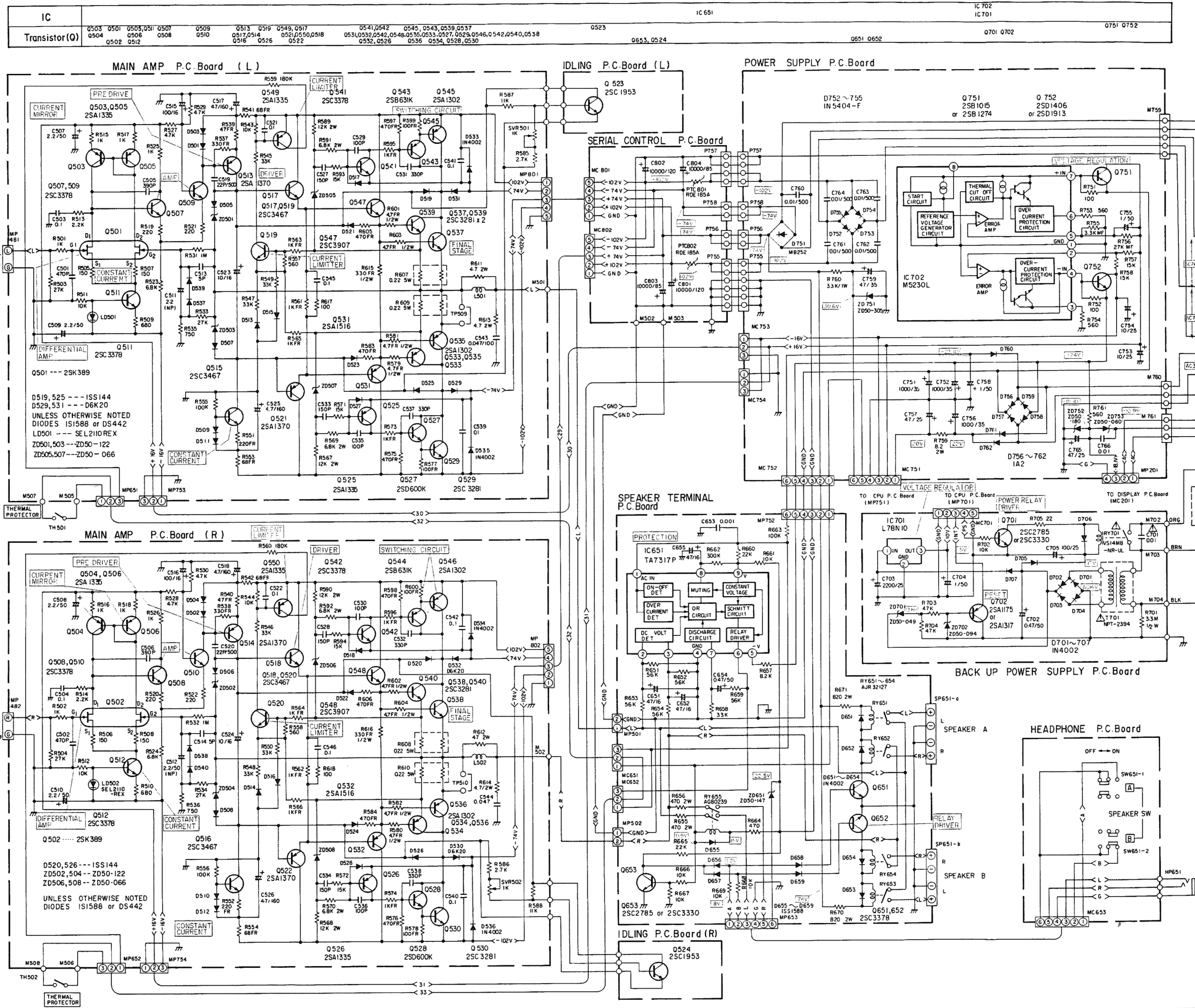

IC 651	IC 702	IC 701
Q501, Q505, Q511, Q507, Q509, Q510, Q513, Q519, Q549, Q517, Q521, Q550, Q518, Q531, Q532, Q542, Q548, Q535, Q533, Q527, Q529, Q546, Q542, Q540, Q538, Q502, Q512	Q523	Q701, Q702
Q541, Q542, Q545, Q543, Q539, Q537	Q524	Q751, Q752
Q532, Q526	Q651, Q652	

MAIN AMP P.C. Board (L)

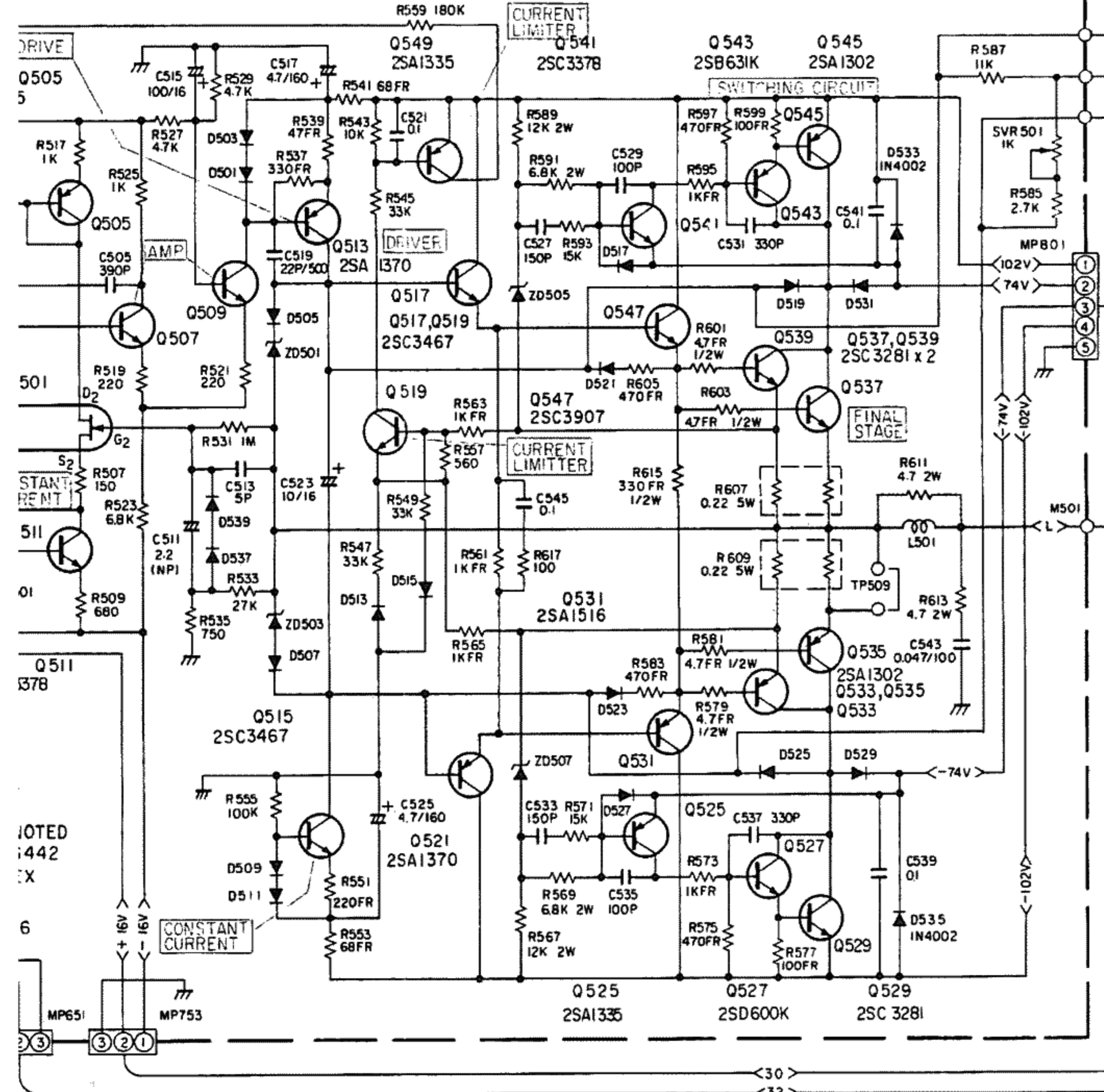

IDLING P.C. Board (L)

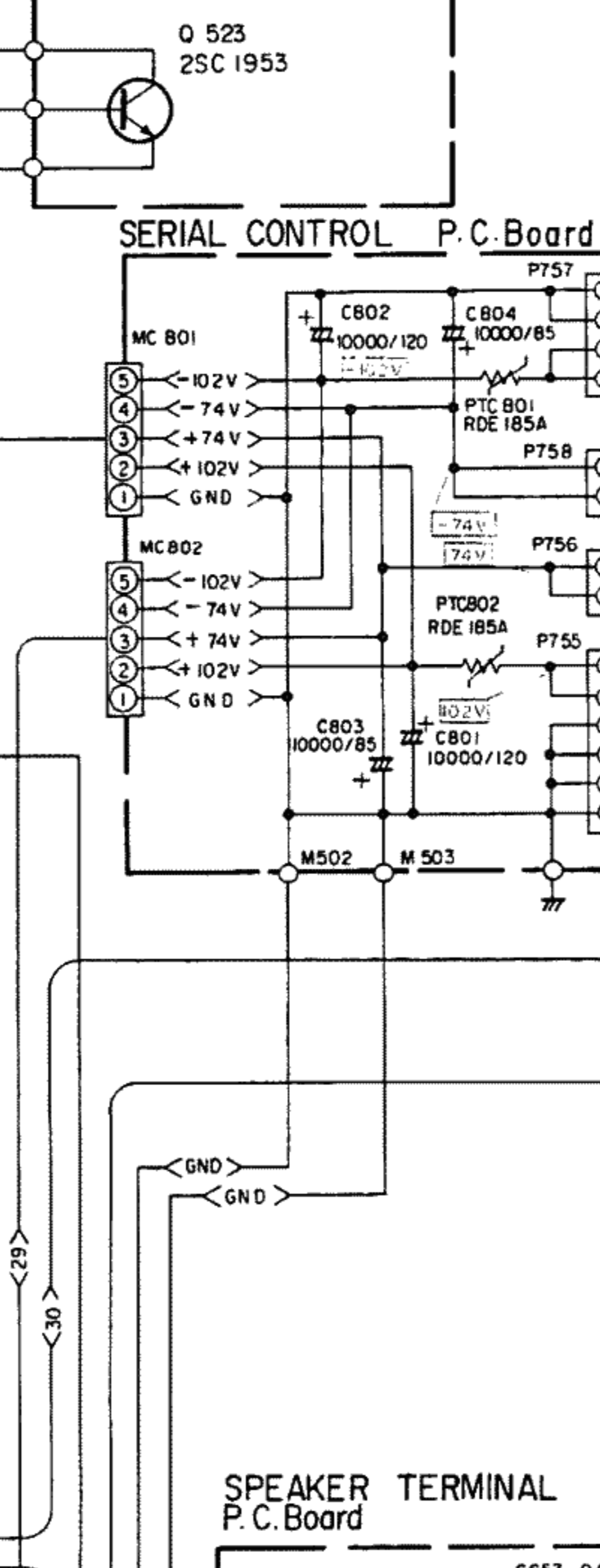

POWER SUPPLY P.C. Board

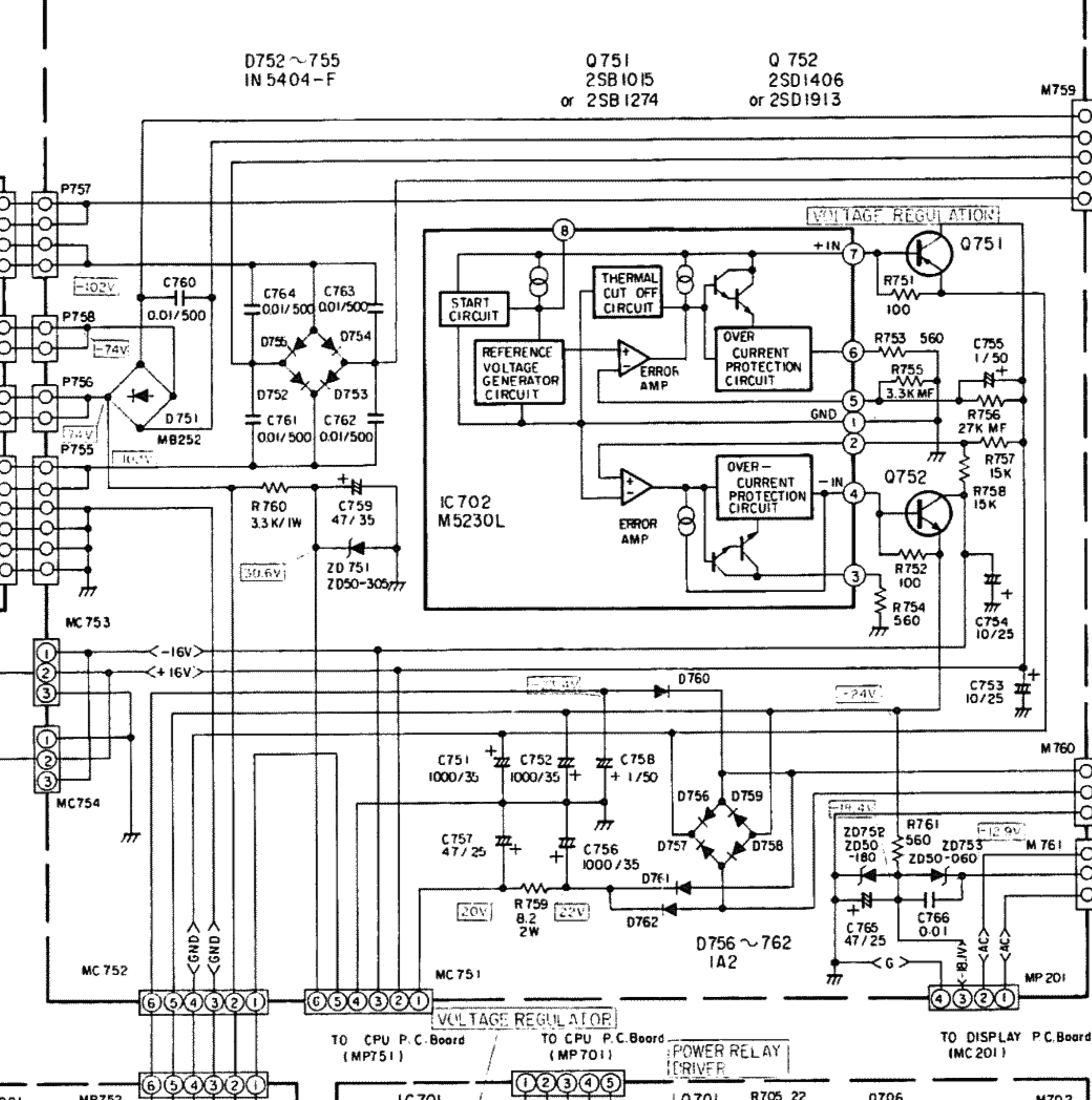

IC 651

1	0.6V
2	0V
3	0V
4	0V
5	-0.6V
6	0.9V
7	0V
8	1.2V
9	

IC 702

1	0V
2	0V
3	-3.4V
4	23.6V
5	1.7V
6	2.8V
7	22.4V
8	0V

IC 701

1	1.6V
2	0V
3	10V

	E	C	B
Q502	15.2V	7.9V	14.6V
Q504	15.2V	7.9V	14.6V
Q505	15.2V	14.6V	14.6V
Q506	15.2V	14.6V	14.6V
Q507	7.3V	14.7V	7.9V
Q508	7.3V	14.7V	7.9V
Q509	7.3V	100.9V	8V
Q510	7.3V	100.9V	8V
Q511	-14.7V	0V	-14.1V
Q512	-14.7V	0V	-14.1V
Q513	101.5V	1.2V	100.9V
Q514	101.5V	1.2V	100.9V
Q515	-101.2V	-1.2V	-100.6V
Q516	-101.2V	-1.2V	-100.6V
Q517	0.6V	102V	1.2V
Q518	0.6V	102V	1.2V
Q519	0V	102V	0V
Q520	0V	102V	0V
Q521	-0.6V	-102V	-1.2V
Q522	-0.6V	-102V	-1.2V
Q523	-1.2V	1.5V	-0.5V
Q524	-1.2V	1.2V	-0.5V
Q525	-74V	-102V	-72.6V
Q526	-74V	-102V	-72.6V
Q527	-102V	-73.4V	-102V
Q528	-102V	-73.4V	-102V
Q529	-102V	-73.4V	-102V
Q530	-102V	-73.4V	-102V
Q531	-0.6V	-102V	-0.6V
Q532	-0.6V	-102V	-0.6V
Q533	0V	-73.4V	-0.2V
Q534	0V	-73.4V	-0.2V
Q535	0V	-73.4V	-0.2V
Q536	0V	-73.4V	-0.2V
Q537	0V	73.4V	0.2V
Q538	0V	73.4V	0.2V
Q539	0V	73.4V	0.2V
Q540	0V	73.4V	0.2V
Q541	74V	102V	72.6V
Q542	74V	102V	72.6V
Q543	102V	73.4V	102V
Q544	102V	73.4V	102V
Q545	102V	73.4V	102V
Q546	102V	73.4V	102V
Q547	0.2V	102V	0.6V
Q548	0.2V	102V	0.6V
Q549	102V	102V	102V
Q550	102V	102V	102V
Q651	0V	74V	0V
Q652	0V	0V	0.6V
Q653	0V	22.7V	0.6V
Q701	0V	0V	0.6V
Q702	5V	0V	9.5V
Q751	23V	16V	22.4V
Q752	-24V	-16V	23.6V

AMP P.C. Board (R)

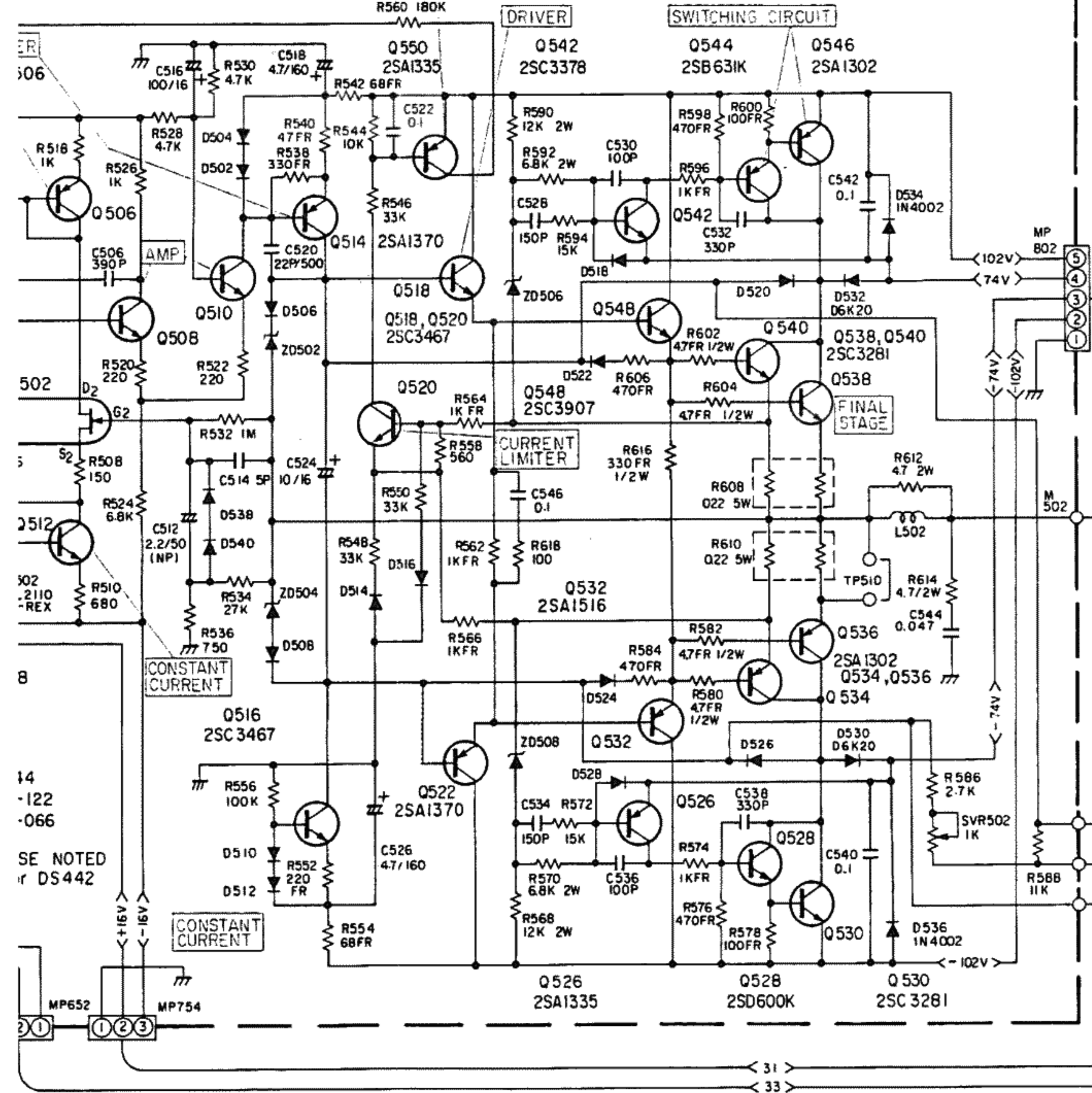

SERIAL CONTROL P.C. Board

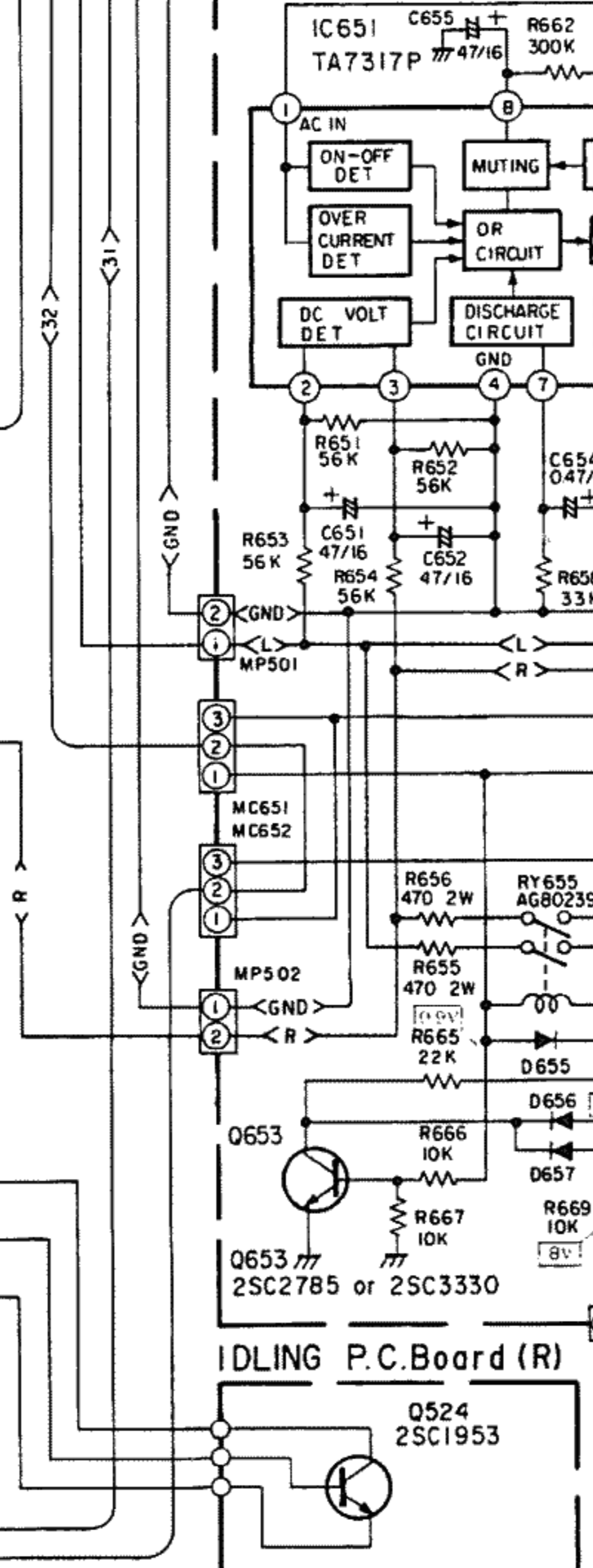

SPEAKER TERMINAL P.C. Board

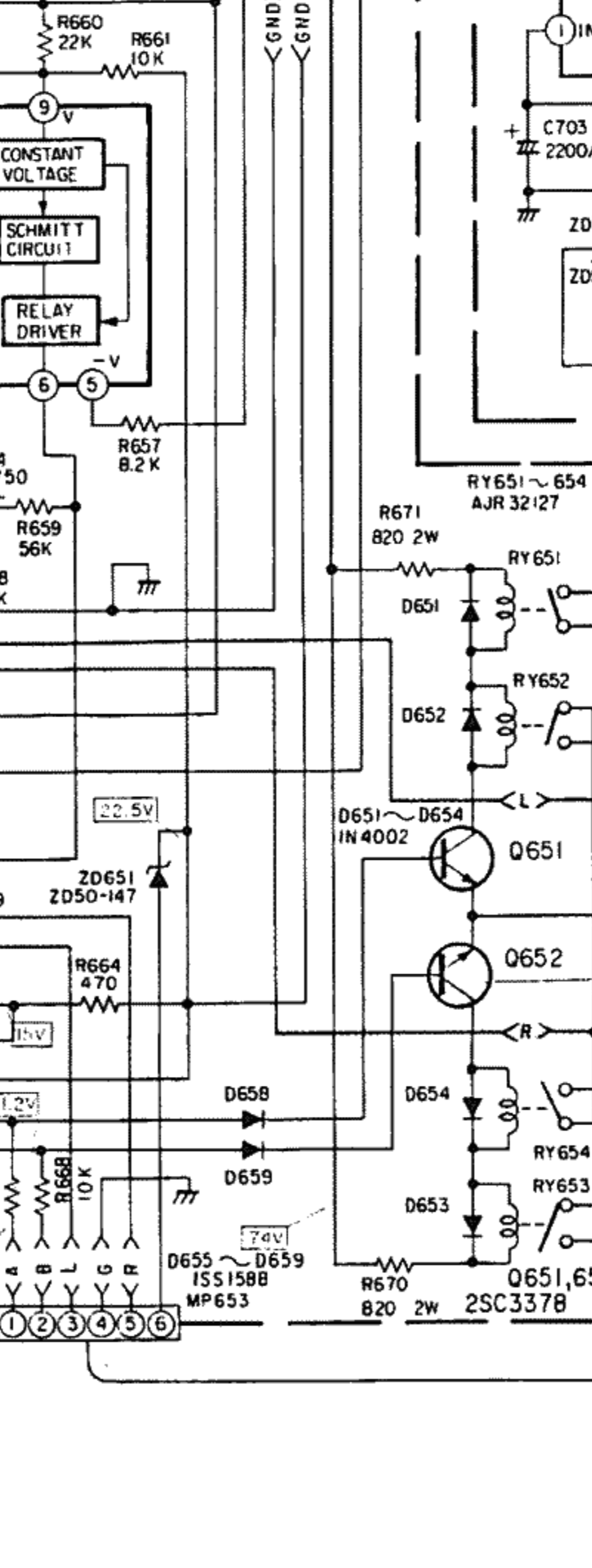

BACK UP POWER SUPPLY P.C. Board

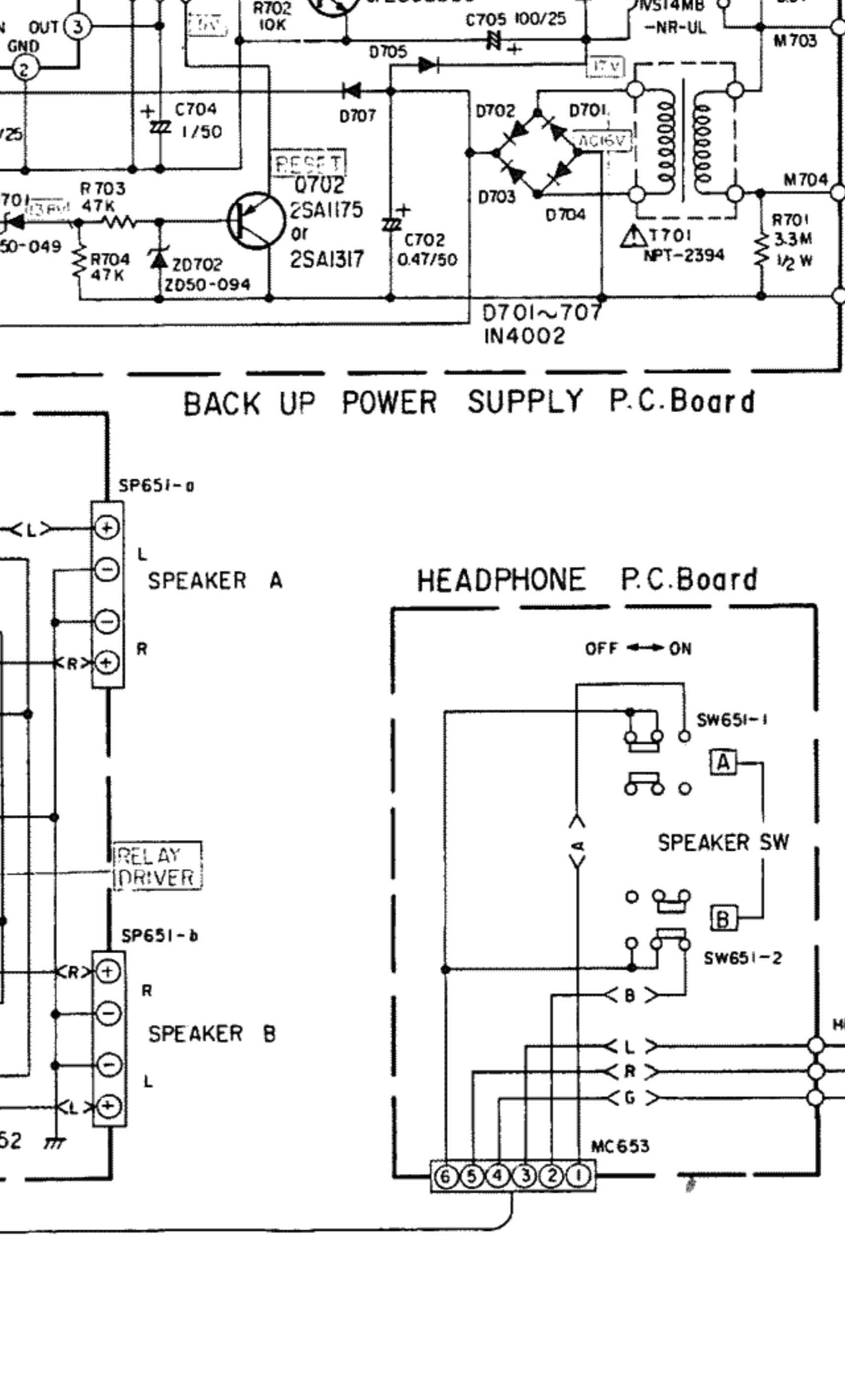

HEADPHONE P.C. Board

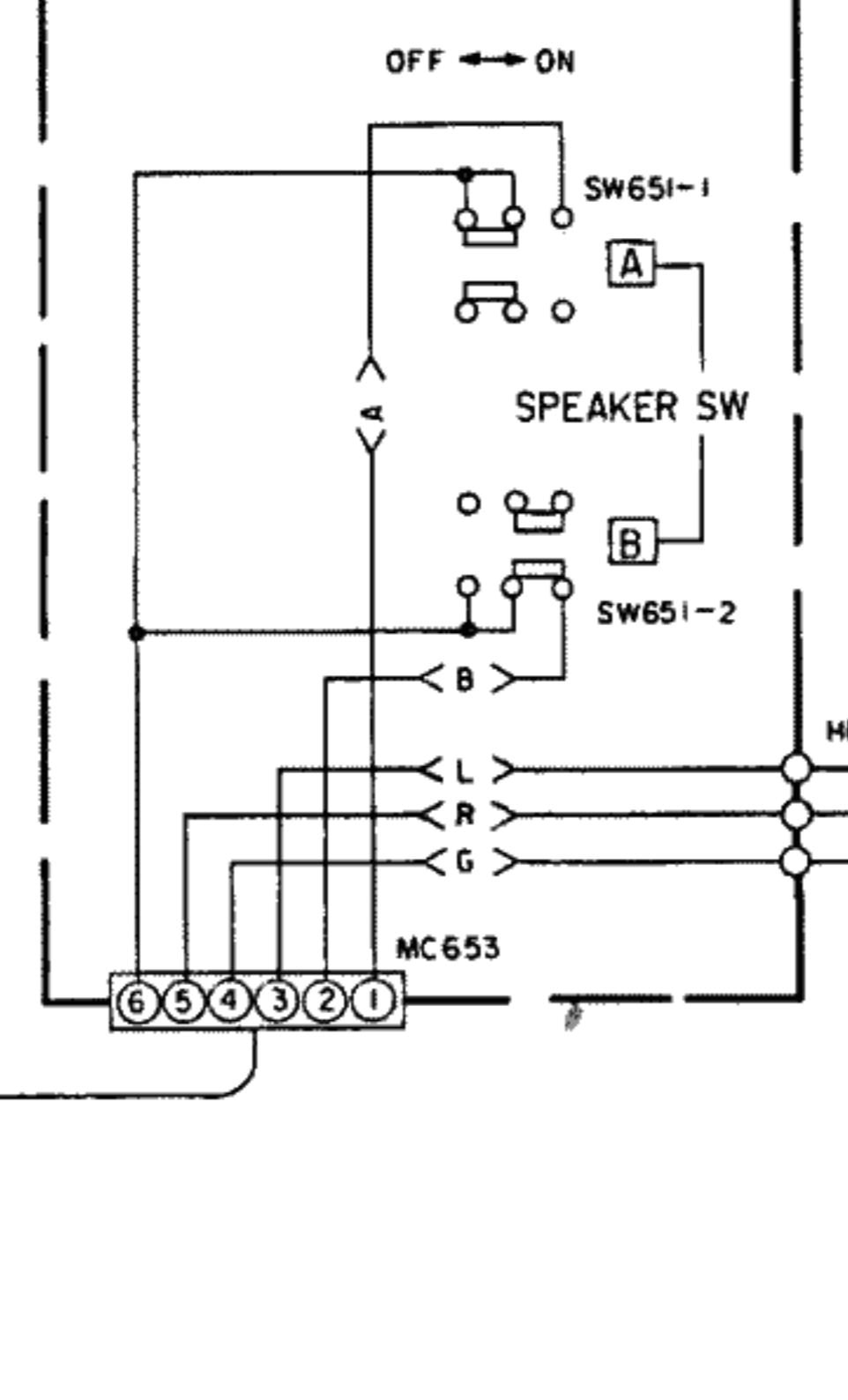

Q601

D1	G1	S1
7.9V	0V	0.2V
D2	C2	S2
14.6V	0V	0.2V

Q502

D1	G1	S1
7.9V	0V	0.2V
D2	C2	S2
14.6V	0V	0.2V

- NOTES
- UNLESS OTHERWISE NOTICED ALL DIODES ARE 1N4001 OR 1SS116.
 - All resistors are 1/4 watt or 1/8 watt $\pm 5\%$ unless otherwise. Resistor values are in ohms. (K=1000 ohms, M=1000K ohms)
 - All capacitor values are in microfarads. (P=picofarads)
 - Each DC voltage shows the nominal values in volts no input signal.
 - Δ is safety part. Use only replacement parts recommended by manufacturer.

Parts Layout on P.C. Boards and Wiring Diagram (1/3)



- BLU Blue
- GRN Green
- BLK Black
- GRY Gray
- WHT White
- RED Red
- BRN Brown
- ORG Orange
- YEL Yellow
- PNK Pink
- VIO Violet
- GRN/WHT Green/White
- GRY/WHT Gray/White
- GRY/YEL Gray/Yellow
- GRN/YEL Green/Yellow
- SHLD Shield

Parts Layout on P.C. Boards and Wiring Diagram (2/3)

- BLU Blue
- GRN Green
- BLK Black
- GRY Gray
- WHT White
- RED Red
- BRN Brown
- ORG Orange
- YEL Yellow
- PNK Pink
- VIO Violet
- GRN/WHT Green/White
- GRY/WHT Gray/White
- GRY/YEL Gray/Yellow
- GRN/YEL Green/Yellow
- SHLD Shield

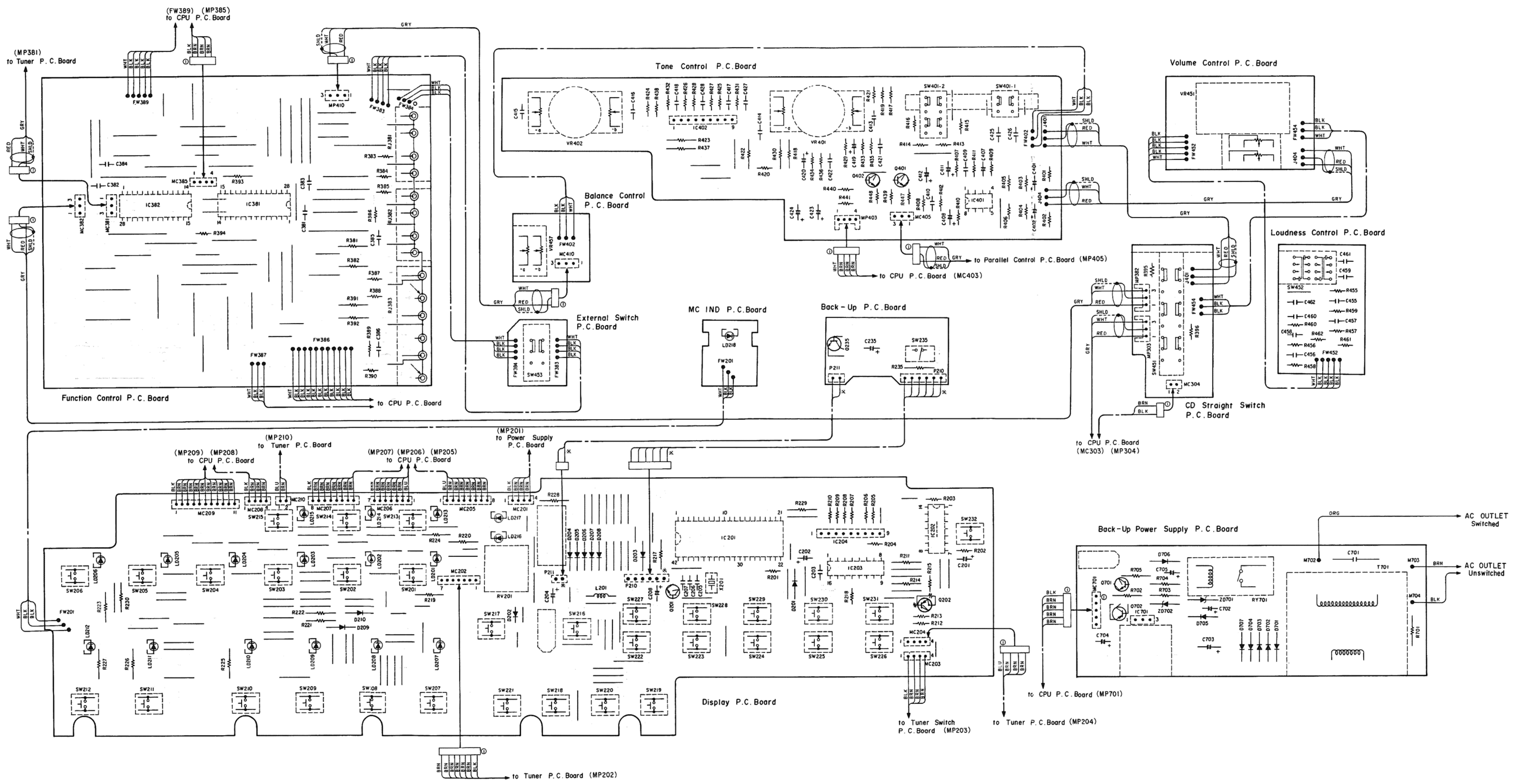

Parts Layout on P.C. Boards and Wiring Diagram (3/3)



Symbol No.	Part No.	Description			Symbol No.	Part No.	Description		
C529	21E04358S01	CER., 100pF			Main Amp P. C. Board (R)				
C531	21E04366S01	CER., 330pF			Transistors				
C533	21E04360S01	CER., 150pF			Q502	48E04195S01	FET, 2SK389		
C535	21E04358S01	CER., 100pF			Q504	48E04174S01	2SA1335		
C537	21E04366S01	CER., 330pF			Q506	48E04174S01	2SA1335		
C539	08E04349S01	MYL., 0.1 μ F			Q508	48E04187S01	2SC3378		
C541	08E04349S01	MYL., 0.1 μ F			Q510	48E04187S01	2SC3378		
C543	08E04349S02	MYL., 0.047 μ F			Q512	48E04187S01	2SC3378		
C545	08E04346S01	M.F., 0.1 μ F			Q514	48E04401S01	2SA1370		
Resistors					Q516	48E04404S01	2SC3467		
R537	06E04321S04	F.R., 330 ohm 1/4W			Q518	48E04404S01	2SC3467		
R539	06E04321S08	F.R., 47 ohm 1/4W			Q520	48E04404S01	2SC3467		
R541	06E04321S06	F.R., 68 ohm 1/4W			Q522	48E04401S01	2SA1370		
R551	06E04321S07	F.R., 220 ohm 1/4W			Q526	48E04174S01	2SA1335		
R553	06E04321S06	F.R., 68 ohm 1/4W			Q528	48E04191S01	2SD600K		
R561	06E04321S02	F.R., 1k ohm 1/4W			Q530	48E04403S01	2SC3281		
R563	06E04321S02	F.R., 1k ohm 1/4W			Q532	48E04402S01	2SA1516		
R565	06E04321S02	F.R., 1k ohm 1/4W			Q534	48E04400S01	2SA1302		
R567	06E04320S04	M.O., 12k ohm 2W			Q536	48E04400S01	2SA1302		
R569	06E04320S05	M.O., 6.8k ohm 2W			Q538	48E04403S01	2SC3281		
R573	06E04321S02	F.R., 1k ohm 1/4W			Q540	48E04403S01	2SC3281		
R575	06E04321S05	F.R., 470 ohm 1/4W			Q542	48E04187S01	2SC3378		
R577	06E04321S01	F.R., 100 ohm 1/4W			Q544	48E04178S01	2SB631K		
R579	06E04322S05	F.R., 4.7 ohm 1/2W			Q546	48E04400S01	2SA1302		
R581	06E04322S05	F.R., 4.7 ohm 1/2W			Q548	48E04405S01	2SC3907		
R583	06E04321S05	F.R., 470 ohm 1/4W			Q550	48E04174S01	2SA1335		
R589	06E04320S04	M.O., 12k ohm 2W			Diodes/LED				
R591	06E04320S05	M.O., 6.8k ohm 2W			D502	48E04212S01	1S1588		
R595	06E04321S02	F.R., 1k ohm 1/4W			D504	48E04212S01	1S1588		
R597	06E04321S05	F.R., 470 ohm 1/4W			D506	48E04212S01	1S1588		
R599	06E04321S01	F.R., 100 ohm 1/4W			D508	48E04212S01	1S1588		
R601	06E04322S05	F.R., 4.7 ohm 1/2W			D510	48E04212S01	1S1588		
R603	06E04322S05	F.R., 4.7 ohm 1/2W			D512	48E04212S01	1S1588		
R605	06E04321S05	F.R., 470 ohm 1/4W			D514	48E04212S01	1S1588		
R607	06E04323S01	C.E., 0.22 ohm 5W			D516	48E04212S01	1S1588		
R609	06E04323S01	C.E., 0.22 ohm 5W			D518	48E04212S01	1S1588		
R611	06E04320S01	M.O., 4.7 ohm 2W			D520	48E04211S01	1SS144		
R613	06E04320S01	M.O., 4.7 ohm 2W			D522	48E04212S01	1S1588		
R615	06E04322S04	F.R., 330 ohm 1/2W			D524	48E04212S01	1S1588		
SVR501	18E04324S01	Variable, 1k ohm			D526	48E04211S01	1SS144		
					D528	48E04212S01	1S1588		
					D530	48E04406S01	D6K20		
					D532	48E04406S01	D6K20		
					D534	48E04209S01	1N4002		
					D536	48E04209S01	1N4002		
					D538	48E04212S02	1S1588		
					D540	48E04212S02	1S1588		

Symbol No.	Part No.	Description		
LD502	48E04215S01	LED. SEL2110REX		
ZD502	48E04408S01	Zener. 1/2W. 12.2V. ZD50-122		
ZD504	48E04408S01	Zener. 1/2W. 12.2V. ZD50-122		
ZD506	48E04203S01	Zener. 1/2W. 6.6V. ZD50-066		
ZD508	48E04203S01	Zener. 1/2W. 6.6V. ZD50-066		
Thermal Switch/Coil				
TH502	80E04315S01	Relay. Thermal U12-10075-200A		
L502	24E04241S01	Coil. AIR-CORE. 0.1 μ H		
Capacitors				
C502	21E04364S02	CER., 470pF		
C504	08E04348S02	MYL., 0.1 μ F		
C506	21E04364S01	CER., 390pF		
C508	23E04338S06	ELY., 2.2 μ F/50V		
C510	23E04338S06	ELY., 2.2 μ F/50V		
C512	23E04331S01	ELY., (NP) 2.2 μ F/50V		
C514	21E04354S01	CER., 5pF		
C516	23E04335S02	ELY., 100 μ F/16V		
C518	23E04429S01	ELY., 4.7 μ F/160V		
C520	21E04368S01	CER., 22pF		
C522	08E04346S01	M.F., 0.1 μ F		
C524	23E04335S01	ELY., 10 μ F/16V		
C526	23E04429S01	ELY., 4.7 μ F/160V		
C528	21E04360S01	CER., 150pF		
C530	21E04358S01	CER., 100pF		
C532	21E04366S01	CER., 330pF		
C534	21E04360S01	CER., 150pF		
C536	21E04358S01	CER., 100pF		
C538	21E04366S01	CER., 330pF		
C540	08E04349S01	MYL., 0.1 μ F		
C542	08E04349S01	MYL., 0.1 μ F		
C544	08E04349S02	MYL., 0.047 μ F		
C546	08E04346S01	Metallized Film 0.1 μ F		

Symbol No.	Part No.	Description		
Resistors				
R538	06E04321S04	F.R., 330 ohm 1/4W		
R540	06E04321S08	F.R., 47 ohm 1/4W		
R542	06E04321S06	F.R., 68 ohm 1/4W		
R552	06E04321S07	F.R., 220 ohm 1/4W		
R554	06E04321S06	F.R., 68 ohm 1/4W		
R562	06E04321S02	F.R., 1k ohm 1/4W		
R564	06E04321S02	F.R., 1k ohm 1/4W		
R566	06E04321S02	F.R., 1k ohm 1/4W		
R568	06E04320S04	M.O., 12k ohm 2W		
R570	06E04320S05	M.O., 6.8k ohm 2W		
R574	06E04321S02	F.R., 1k ohm 1/4W		
R576	06E04321S05	F.R., 470 ohm 1/4W		
R578	06E04321S01	F.R., 100 ohm 1/4W		
R580	06E04322S05	F.R., 4.7 ohm 1/2W		
R582	06E04322S05	F.R., 4.7 ohm 1/2W		
R584	06E04321S05	F.R., 470 ohm 1/4W		
R590	06E04320S04	M.O., 12k ohm 2W		
R592	06E04320S05	M.O., 6.8k ohm 2W		
R596	06E04321S02	F.R., 1k ohm 1/4W		
R598	06E04321S05	F.R., 470 ohm 1/4W		
R600	06E04321S01	F.R., 100 ohm 1/4W		
R602	06E04322S05	F.R., 4.7 ohm 1/2W		
R604	06E04322S05	F.R., 4.7 ohm 1/2W		
R606	06E04321S05	F.R., 470 ohm 1/4W		
R608	06E04323S01	C.E., 22k ohm		
R610	06E04323S01	C.E., 0.22 ohm 5W		
R612	06E04320S01	M.O., 4.7 ohm 2W		
R614	06E04320S01	M.O., 4.7 ohm 2W		
R616	06E04322S04	F.R., 330 ohm 1/2W		
SVR502	18E04324S01	Variable, 1k ohm		
Idling P. C. Board (L)				
Transistor				
Q523	48E04180S01	2SC1953		
Idling P. C. Board (R)				
Transistor				
Q524	48E04180S01	2SC1953		
Power Supply P. C. Board				
IC/Transistors				
IC702	51E04232S01	M5230L		
Q751	48E04176S01	2SB1274		
Q752	48E04189S01	2SD1913		

Symbol No.	Part No.	Description		
Diodes				
D751	48E04198S01	MB252		
D752	48E04410S01	1N5404-F		
D753	48E04410S01	1N5404-F		
D754	48E04410S01	1N5404-F		
D755	48E04410S01	1N5404-F		
D756	48E04208S01	1A2		
D757	48E04208S01	1A2		
D758	48E04208S01	1A2		
D759	48E04208S01	1A2		
D760	48E04208S01	1A2		
D761	48E04208S01	1A2		
D762	48E04208S01	1A2		
ZD751	48E04207S01	Zener, 1/2W, 30.5V, ZD50-305		
ZD752	48E04206S01	Zener, 1/2W, 18.0V, ZD50-180		
ZD753	48E04201S01	Zener, 1/2W, 6.0V, ZD50-060		

Capacitors				
C751	23E04337S01	ELY., 1000 μ F/35V		
C752	23E04337S01	ELY., 1000 μ F/35V		
C753	23E04336S01	ELY., 10 μ F/25V		
C754	23E04336S01	ELY., 10 μ F/25V		
C755	23E04338S04	ELY., 1 μ F/50V		
C756	23E04337S01	ELY., 1000 μ F/35V		
C757	23E04336S06	ELY., 47 μ F/25V		
C758	23E04338S04	ELY., 1 μ F/50V		
C759	23E04337S02	ELY., 47 μ F/35V		
C760	21E04367S01	CER., 0.01 μ F		
C761	21E04367S01	CER., 0.01 μ F		
C762	21E04367S01	CER., 0.01 μ F		
C763	21E04367S01	CER., 0.01 μ F		
C764	21E04367S01	CER., 0.01 μ F		
C765	23E04336S06	ELY., 47 μ F/25V		
C766	21E04362S01	CER., 0.01 μ F		

Resistors				
R755	06E04318S02	M.F., 3.3k ohm 1/4W		
R756	06E04318S01	M.F., 27k ohm 1/4W		
R759	06E04298S01	M.O., 8.2 ohm 2W		
R760	06E04319S03	M.O., 3.3k ohm 1W		

Symbol No.	Part No.	Description		
Speaker Terminal P. C. Board				
IC/Transistors				
IC651	51E04233S01	TA7317P		
Q651	48E04187S01	2SC3378		
Q652	48E04187S01	2SC3378		
Q653	48E04183S01	2SC2785		

Diodes				
D651	48E04209S01	1N4002		
D652	48E04209S01	1N4002		
D653	48E04209S01	1N4002		
D654	48E04209S01	1N4002		
D655	48E04212S01	1S1588		
D656	48E04212S01	1S1588		
D657	48E04212S01	1S1588		
D658	48E04212S01	1S1588		
D659	48E04212S01	1S1588		
ZD651	48E04409S01	Zener, 1/2W, 14.7V, ZD50-147		

Capacitors				
C651	23E04335S04	ELY., 47 μ F/16V		
C652	23E04335S04	ELY., 47 μ F/16V		
C653	21E04356S01	CER., 1000pF		
C654	23E04338S03	ELY., 0.47 μ F/50V		
C655	23E04335S04	ELY., 47 μ F/16V		

Resistors				
R655	06E04320S02	M.O., 470 ohm 2W		
R656	06E04320S02	M.O., 470 ohm 2W		
R670	06E04320S06	M.O., 820 ohm 2W		
R671	06E04320S06	M.O., 820 ohm 2W		

Relays/Socket				
RY651	80E04425S01	Relay, AJR32127		
RY652	80E04425S01	Relay, AJR32127		
RY653	80E04425S01	Relay, AJR32127		
RY654	80E04425S01	Relay, AJR32127		
RY655	80E04424S01	Relay, AG80239		
SP651	09E04297S01	Socket 8P (S.P.) YKD31-0363		

Symbol No.	Part No.	Description		
Back Up Power Supply P. C. Board				
IC/Transistors				
IC701	51E04230S01	L78N10		
Q701	48E04183S01	2SC2785		
Q702	48E04171S01	2SA1175		
Diodes				
D701	48E04209S01	1N4002		
D702	48E04209S01	1N4002		
D703	48E04209S01	1N4002		
D704	48E04209S01	1N4002		
D705	48E04209S01	1N4002		
D706	48E04209S01	1N4002		
D707	48E04209S01	1N4002		
ZD701	48E04199S01	Zener, 1/2W, 4.9V, ZD50-049		
ZD702	48E04205S01	Zener, 1/2W, 9.4V, ZD50-094		
Capacitors/Resistor				
C701	08E04371S01	M.F., 0.01 μ F		
C702	23E04338S03	ELY., 0.47 μ F/50V		
C703	23E04336S04	ELY., 2200 μ F/25V		
C704	23E04338S04	ELY., 1 μ F/50V		
C705	23E04336S02	ELY., 100 μ F/25V		
R701	06E04316S01	C.F, 3.3M ohm 1/2W		
Relay/Coil				
RY701	80E04426S01	VS14MB-NR-UL		
T701	25E04299S01	Power Trans		
Headphone P. C. Board				
Switch				
SW651	40E04415S01	Push Switch, SW-1201205		

Symbol No.	Part No.	Description		
Jack				
HP651	09E04372S01	H.P. YKB24-5010		
CPU P. C. Board				
IC's				
IC301	51E04238S01	μ PC4570HA-1		
IC302	51E04412S01	μ PD75104CW-095		
IC303	51E04226S01	LC4001B		
IC304	51E04218S01	HD74145P		
IC305	51E04217S01	DN74LS145		
IC306	51E04225S01	LB1645N		
IC307	51E04231S01	L78N12		
IC308	51E04231S01	L78N12		
IC309	51E04229S01	L78N05		
IC311	51E04226S01	LC4001B		
Transistors				
Q301	48E04193S01	FET, 2SK170		
Q302	48E04193S01	FET, 2SK170		
Q303	48E04193S01	FET, 2SK170		
Q304	48E04193S01	FET, 2SK170		
Q305	48E04175S01	2SA1345		
Q306	48E04188S01	2SC3399		
Q307	48E04177S01	2SB621NC		
Q308	48E04188S01	2SC3399		
Q309	48E04188S01	2SC3399		
Q310	48E04188S01	2SC3399		
Q311	48E04188S01	2SC3399		
Q312	48E04188S01	2SC3399		
Q313	48E04188S01	2SC3399		
Q314	48E04188S01	2SC3399		
Q315	48E04188S01	2SC3399		
Q316	48E04175S01	2SA1345		
Q317	48E04184S01	2SC2878		
Q318	48E04184S01	2SC2878		
Q403	48E04175S01	2SA1345		
Q451	48E04188S01	2SC3399		
Q452	48E04188S01	2SC3399		
Q471	48E04183S01	2SC2785		
Diodes				
D303	48E04208S01	1A2		
D304	48E04208S01	1A2		
D305	48E04208S01	1A2		
D306	48E04208S01	1A2		
D307	48E04208S01	1A2		

Symbol No.	Part No.	Description		
D308	48E04208S01	1A2		
D309	48E04208S01	1A2		
D310	48E04197S01	GMA01		
D311	48E04197S01	GMA01		
D312	48E04197S01	GMA01		
D313	48E04197S01	GMA01		
D315	48E04197S01	GMA01		
D316	48E04197S01	GMA01		
D317	48E04197S01	GMA01		
D318	48E04197S01	GMA01		
D319	48E04197S01	GMA01		
ZD301	48E04200S01	Zener, 1/2W, 5.5V, ZD50-055		

Capacitors

C301	21E04361S02	CER.,	220pF		
C302	21E04361S02	CER.,	220pF		
C303	08E04348S10	MYL.,	1000pF		
C304	08E04348S10	MYL.,	1000pF		
C305	08E04348S05	MYL.,	2700pF		
C306	08E04348S05	MYL.,	2700pF		
C307	23E04334S01	ELY.,	100 μ F/10V		
C309	23E04335S02	ELY.,	100 μ F/16V		
C310	23E04335S02	ELY.,	100 μ F/16V		
C311	23E04333S01	ELY.,	10 μ F/16V		
C312	23E04333S01	ELY.,	10 μ F/16V		
C313	08E04348S06	MYL.,	0.027 μ F		
C314	08E04348S06	MYL.,	0.027 μ F		
C315	08E04348S09	MYL.,	7500pF		
C316	08E04348S09	MYL.,	7500pF		
C317	08E04348S03	MYL.,	1200pF		
C318	08E04348S03	MYL.,	1200pF		
C319	23E04336S03	ELY.,	22 μ F/25V		
C320	08E04346S01	M.F.,	0.1 μ F		
C321	08E04346S01	M.F.,	0.1 μ F		
C322	23E04338S04	ELY.,	1 μ F/50V		
C323	08E04346S01	M.F.,	0.1 μ F		
C324	08E04348S01	MYL.,	0.01 μ F		
C325	08E04346S01	M.F.,	0.1 μ F		
C326	23E04338S04	ELY.,	1 μ F/50V		
C327	23E04332S02	ELY.,	22000 μ F/5.5V		
C328	21E04362S01	CER.,	0.01 μ F		
C329	23E04340S01	ELY.,	2200 μ F/6.3V		
C330	21E04362S01	CER.,	0.01 μ F		
C331	21E04362S01	CER.,	0.01 μ F		
C332	21E04357S02	CER.,	33pF		
C333	21E04357S02	CER.,	33pF		
C334	23E04336S01	ELY.,	10 μ F/25V		
C335	23E04338S06	ELY.,	2.2 μ F/50V		
C336	23E04336S03	ELY.,	22 μ F/25V		

Symbol No.	Part No.	Description			
C337	23E04336S03	ELY.,	22 μ F/25V		
C338	21E04352S01	CER.,	0.047 μ F		
C339	21E04352S01	CER.,	0.047 μ F		
C340	23E04333S02	ELY.,	4.7 μ F/25V		
C341	21E04362S01	CER.,	0.01 μ F		
C342	21E04362S01	CER.,	0.01 μ F		
C343	23E04338S04	ELY.,	1 μ F/50V		
C344	23E04336S01	ELY.,	10 μ F/25V		
C345	21E04362S01	CER.,	0.01 μ F		

Resistors

R317	06E04317S01	M.F.,	210 ohm 1/6W		
R318	06E04317S01	M.F.,	210 ohm 1/6W		
R346	06E04322S01	F.R.,	10 ohm 1/2W		
R347	06E04322S01	F.R.,	10 ohm 1/2W		
R348	06E04322S06	F.R.,	12 ohm 1/2W		
RA301	06E04328S01	Block,	100k ohm x 8		
RA302	06E04327S01	Block,	100k ohm x 7		
RA303	06E04326S01	Block,	22k ohm x 4		
RA304	06E04326S01	Block,	22k ohm x 4		

Jacks/Relays/Filter

RJ301	09E04287S01	RCA JACK 6P. T6060-AACA			
RJ302	09E04287S01	RCA JACK 6P. T6060-AACA			
RY301	80E04424S01	Relay, AG80239			
RY302	80E04424S01	Relay, AG80239			
CF301	91E04269S01	Filter, KBR-4.19Ms			

Function Control P. C. Board

IC's

IC381	51E04234S01	TC9163N			
IC382	51E04411S01	TC9164N			

Capacitors

C381	23E04336S06	ELY.,	47 μ F/25V		
C382	21E04362S01	CER.,	0.01 μ F		
C383	23E04336S06	ELY.,	47 μ F/25V		
C384	21E04362S01	CER.,	0.01 μ F		
C385	21E04352S01	CER.,	0.047 μ F		
C386	21E04352S01	CER.,	0.047 μ F		

Symbol No.	Part No.	Description		
Jacks				
RJ381	09E04285S01	RCA 4P. T5812-FA		
RJ382	09E04418S01	RCA 4P. T6005-AABA		
RJ383	09E04420S01	RCA 6P. T6277-ADBA		
Tone Control P. C. Board				
IC's/Transistors/Switch				
IC401	51E04237S01	μ PC4570C-1		
IC402	51E04238S01	μ PC4570HA-1		
Q401	48E04184S01	2SC2878		
Q402	48E04184S01	2SC2878		
SW401	40E04275S01	Push Switch, SW-1201206		
Capacitors				
C401	23E04342S01	ELY., 2.2 μ F/50V		
C402	23E04342S01	ELY., 2.2 μ F/50V		
C407	23E04343S01	ELY., 10 μ F/16V		
C408	23E04343S01	ELY., 10 μ F/16V		
C409	21E04354S03	CER., 47pF		
C410	21E04354S03	CER., 47pF		
C411	23E04341S01	ELY., 10 μ F/16V		
C412	23E04341S01	ELY., 10 μ F/16V		
C413	08E04348S01	MYL., 0.01 μ F		
C414	08E04348S01	MYL., 0.01 μ F		
C415	08E04346S03	M.F., 0.082 μ F		
C416	08E04346S03	M.F., 0.082 μ F		
C417	21E04354S02	CER., 7pF		
C418	21E04354S02	CER., 7pF		
C419	23E04345S01	ELY., 1 μ F/50V		
C420	23E04345S01	ELY., 1 μ F/50V		
C421	08E04348S07	MYL., 3300pF		
C422	08E04348S07	MYL., 3300pF		
C423	23E04344S01	ELY., 22 μ F/25V		
C424	23E04344S01	ELY., 22 μ F/25V		
C425	08E04346S02	M.F., 0.12 μ F		
C426	08E04346S02	M.F., 0.12 μ F		
C427	21E04362S01	CER., 0.01 μ F		
C428	21E04362S01	CER., 0.01 μ F		

Symbol No.	Part No.	Description		
Resistors				
VR401	18E04272S01	Variable, Rotary Potentionmeter, VCT16-203B21F7		
VR402	18E04272S01	Variable, Rotary Potentionmeter, VCT16-203B21F7		
Volume Control P. C. Board				
Resistor				
VR451	18E04270S01	Variable, Rotary Potentionmeter, EUW-MLG337BC5		
Volume IND P. C. Board				
LED				
LD451	48E04216S01	SLR-34VC5F		
External Switch P. C. Board				
Switch				
SW453	40E04278S01	Slide Switch, SSB022		
Balance Control P. C. Board				
Resistor				
VR457	18E04271S01	Variable, 200k ohm, Rotary Potentionmeter, VBB16-204MN1F7		
Parallel Control P. C. Board				
Diodes				
D481	48E04197S01	GMA01		
D482	48E04197S01	GMA01		

Symbol No.	Part No.	Description			Symbol No.	Part No.	Description		
Jacks					IC151	51E04228S01	LM7000		
DJ481	09E04295S01	DIN 5P, CS4450-01-1111			IC152	51E04223S01	LA6458SS		
DJ482	09E04296S01	DIN 8P, CS4490-01-1111			Transistors				
RJ481	09E04417S01	RCA 6P, T5916-AADA			Q001	48E04181S01	2SC2668		
MC Switch P. C. Board					Q002	48E04181S01	2SC2668		
Switch					Q003	48E04181S01	2SC2668		
SW301	40E04414S01	Push Switch, SW-1101203			Q004	48E04181S01	2SC2668		
CD Straight Switch P. C. Board					Q005	48E04183S01	2SC2785		
Switch					Q006	48E04183S01	2SC2785		
SW451	40E04273S01	Push Switch, SW-1101202			Q007	48E04183S01	2SC2785		
Loudness Control P. C. Board					Q008	48E04183S01	2SC2785		
Switch/Capacitors					Q009	48E04181S01	2SC2668		
SW452	40E04413S01	Rotary Switch, SW-2437207			Q051	48E04192S01	FET, 2SK161		
C455	08E04348S08	MYL..	0.039 μ F		Q052	48E04183S01	2SC2785		
C456	08E04348S08	MYL..	0.039 μ F		Q053	48E04183S01	2SC2785		
C457	08E04348S11	MYL..	0.056 μ F		Q054	48E04181S01	2SC2668		
C458	08E04348S11	MYL..	0.056 μ F		Q101	48E04183S01	2SC2785		
C459	21E04361S01	CER..	220pF		Q102	48E04175S01	2SA1345		
C460	21E04361S01	CER..	220pF		Q103	48E04183S01	2SC2785		
C461	21E04430S01	CER..	100pF		C104	48E04194S01	FET, 2SK381		
C462	21E04430S01	CER..	100pF		Q105	48E04183S01	2SC2785		
Tuner P. C. Board					Q106	48E04183S01	2SC2785		
IC's					Q107	48E04175S01	2SA1345		
IC001	51E04219S01	LA1222			Q108	48E04183S01	2SC2785		
IC002	51E04220S01	LA1235			Q109	48E04175S01	2SA1345		
IC051	51E04221S01	LA1245			Q110	48E04188S01	2SC3399		
IC101	51E04222S01	LA3401			Q151	48E04175S01	2SA1345		
IC102	51E04238S01	μ PC4570HA-1			Q152	48E04183S01	2SC2785		
					Diodes				
					D001	48E04197S01	GMA01		
					D002	48E04197S01	GMA01		
					D003	48E04197S01	GMA01		
					D004	48E04197S01	GMA01		
					D005	48E04197S01	GMA01		
					D006	48E04213S01	1S188FM		
					D007	48E04213S01	1S188FM		
					D008	48E04213S01	1S188FM		
					D009	48E04213S01	1S188FM		
					D101	48E04197S01	GMA01		

Symbol No.	Part No.	Description			Symbol No.	Part No.	Description		
D151	48E04197S01	GMA01			C024	23E04338S04	ELY., 1 μ F/50V		
D152	48E04197S01	GMA01			C025	23E04335S04	ELY., 47 μ F/16V		
D153	48E04197S01	GMA01			C027	21E04357S02	CER., 33pF		
D154	48E04197S01	GMA01			C029	21E04365S01	CER., 0.022 μ F		
D171	48E04213S01	1S188FM			C031	21E04362S01	CER., 0.01 μ F		
D172	48E04213S01	1S188FM			C032	21E04362S01	CER., 0.01 μ F		
D174	48E04197S01	GMA01			C033	21E04365S01	CER., 0.022 μ F		
LD151	48E04215S01	LED, SEL2110REX			C034	23E04338S02	ELY., 0.22 μ F/50V		
VD051	48E04198S01	KV1226-Y			C035	21E04362S01	CER., 0.01 μ F		
VD052	48E04198S01	KV1226-Y			C036	08E04347S02	MYL., 1800pF		
ZD191	48E04202S01	Zener, 1/2W, 6.2V, ZD50-062			C037	21E04355S01	CER., 100pF		
Coils/Trimmers					C038	23E04355S04	ELY., 47 μ F/16V		
L001	24E04244S01	FM DET Coil, 141026			C039	21E04365S01	CER., 0.022 μ F		
L002	24E04245S01	Filter Coil, 143019			C071	21E04353S01	CER., 10pF		
L003	24E04243S01	MW ANT Coil, 126044			C072	21E04365S01	CER., 0.022 μ F		
L004	24E04247S01	MW IFT, 140058			C073	21E04353S03	CER., 15pF		
L005	24E04246S01	MW OSC Coil, 135025			C074	08E04350S01	POLY., 470pF		
L007	24E04248S01	Filter Block, 184018			C075	21E04365S01	CER., 0.022 μ F		
L008	24E04248S01	Filter Block, 184018			C076	23E04336S05	ELY., 4.7 μ F/25V		
TC051	20E04370S01	Trimmer, CTL-6U-010			C077	23E04336S01	ELY., 10 μ F/25V		
TC052	20E04370S01	Trimmer, CTL-6U-010			C078	21E04365S01	CER., 0.022 μ F		
TC151	20E04370S02	Trimmer, CTL-6U-030			C079	23E04338S03	ELY., 0.47 μ F/50V		
Capacitors					C080	21E04365S01	CER., 0.022 μ F		
C001	21E04362S01	CER., 0.01 μ F			C081	21E04351S01	CER., 0.01 μ F		
C002	21E04365S01	CER., 0.022 μ F			C082	08E04347S04	MYL., 0.022 μ F		
C003	21E04365S01	CER., 0.022 μ F			C083	23E04338S02	ELY., 0.22 μ F/50V		
C004	21E04365S01	CER., 0.022 μ F			C084	08E04347S07	MYL., 0.015 μ F		
C005	21E04369S01	CER., 0.022 μ F			C085	23E04335S02	ELY., 100 μ F/16V		
C006	21E04362S01	CER., 0.01 μ F			C086	21E04431S01	CER., 1000pF		
C007	21E04362S01	CER., 0.01 μ F			C087	21E04431S01	CER., 1000pF		
C008	21E04359S01	CER., 1000pF			C088	21E04365S01	CER., 0.022 μ F		
C009	21E04365S01	CER., 0.022 μ F			C089	21E04365S01	CER., 0.022 μ F		
C010	21E04365S01	CER., 0.022 μ F			C090	23E04336S01	ELY., 10 μ F/25V		
C011	21E04365S01	CER., 0.022 μ F			C091	21E04365S01	CER., 0.022 μ F		
C012	23E04338S02	ELY., 0.22 μ F/50V			C092	21E04365S01	CER., 0.022 μ F		
C014	21E04369S01	CER., 0.022 μ F			C093	21E04365S01	CER., 0.022 μ F		
C015	21E04365S01	CER., 0.022 μ F			C094	21E04431S01	CER., 1000pF		
C016	23E04338S04	ELY., 1 μ F/50V			C096	21E04351S01	CER., 0.01 μ F		
C017	21E04365S01	CER., 0.022 μ F			C101	23E04338S01	ELY., 1 μ F/50V		
C018	23E04335S03	ELY., 220 μ F/16V			C102	23E04335S04	ELY., 47 μ F/16V		
C021	21E04353S01	CER., 10pF			C103	08E04347S06	MYL., 0.047 μ F		
C022	23E04338S04	ELY., 1 μ F/50V			C104	23E04335S02	ELY., 100 μ F/16V		
C023	21E04357S02	CER., 33pF			C105	23E04338S04	ELY., 1 μ F/50V		
					C106	23E04338S02	ELY., 0.22 μ F/50V		
					C107	23E04336S05	ELY., 4.7 μ F/25V		
					C108	23E04338S04	ELY., 1 μ F/50V		
					C109	23E04338S04	ELY., 1 μ F/50V		
					C110	23E04333S01	ELY., 10 μ F/16V		
					C111	08E04347S03	MYL., 2200pF		
					C112	08E04347S03	MYL., 2200pF		

NOTE: When replacing varactor diodes, VD51 and VD52 always use a diode with the same rank.

Symbol No.	Part No.	Description			Symbol No.	Part No.	Description		
C113	23E04336S05	ELY., 4.7 μ F/25V			Filters/Crystal				
C114	23E04336S05	ELY., 4.7 μ F/25V			F001	91E04266S01	CER., Filter, SFE10.7MLK-A		
C121	08E04347S05	MYL., 3900pF			F002	91E04266S01	CER., Filter, SFE10.7MLK-A		
C122	08E04347S05	MYL., 3900pF			F003	91E04266S01	CER., Filter, SFE10.7MLK-A		
C123	23E04336S01	ELY., 10 μ F/25V			F004	91E04267S01	CER., Filter, SFE10.7MZ1-A		
C124	23E04336S01	ELY., 10 μ F/25V			F051	91E04264S01	CER., Filter, KBF-450P-4AS		
C125	23E04336S01	ELY., 10 μ F/25V			F101	91E04265S01	CER., Filter, 457kHz, KBR-457HS		
C126	23E04336S01	ELY., 10 μ F/25V			X151	48E04268S01	Quartz Oscillator Unit, HC18/U7.200MHz		
C127	23E04338S04	ELY., 1 μ F/50V			Display P. C. Board				
C129	23E04336S01	ELY., 10 μ F/25V			IC's/Transistors				
C130	23E04336S01	ELY., 10 μ F/25V			IC201	51E04236S01	TC9301AN-008		
C151	21E04363S01	CER., 4700pF			IC202	51E04227S01	LC4066B		
C152	23E04333S03	ELY., 1 μ F/50V			IC203	51E04235S01	TC9173P		
C153	08E04348S04	MYL., 0.022 μ F			IC204	51E04224S01	LB1423N		
C154	23E04336S01	ELY., 10 μ F/25V			Q201	48E04183S01	2SC2785		
C155	23E04338S05	ELY., 10 μ F/50V			Q202	48E04175S01	2SA1345		
C156	23E04334S04	ELY., 47 μ F/10V			Diodes/LEDs				
C157	21E04365S01	CER., 0.022 μ F			D201	48E04197S01	GMA01		
C158	21E04355S01	CER., 100pF			D202	48E04197S01	GMA01		
C159	21E04355S01	CER., 100pF			D203	48E04197S01	GMA01		
C160	21E04355S01	CER., 100pF			D204	48E04197S01	GMA01		
C161	21E04355S01	CER., 100pF			D205	48E04197S01	GMA01		
C162	21E04357S02	CER., 33pF			D206	48E04197S01	GMA01		
C163	21E04353S03	CER., 15pF			D207	48E04197S01	GMA01		
C171	23E04338S01	ELY., 1 μ F/50V			D208	48E04197S01	GMA01		
C172	23E04338S04	ELY., 1 μ F/50V			D209	48E04197S01	GMA01		
C173	23E04336S05	ELY., 4.7 μ F/25V			D210	48E04197S01	GMA01		
C191	23E04336S01	ELY., 10 μ F/25V			LD201	48E04216S01	LED, SLR-34VC5F		
C192	23E04336S01	ELY., 10 μ F/25V			LD202	48E04216S01	LED, SLR-34VC5F		
Resistors					LD203	48E04216S01	LED, SLR-34VC5F		
SVR001	18E04324S02	Semi-Variable, RHO614C-103			LD204	48E04216S01	LED, SLR-34VC5F		
SVR102	18E04325S03	Semi-Variable, SVR-06T3B504			LD205	48E04216S01	LED, SLR-34VC5F		
SVR103	18E04325S04	Semi-Variable SVR-06T3B504CM			LD206	48E04216S01	LED, SLR-34VC5F		
SVR104	18E04325S04	Semi-Variable SVR-06T3B504CM			LD207	48E04216S01	LED, SLR-34VC5F		
SVR151	18E04325S01	Semi-Variable, SVR-06T3B223			LD208	48E04216S01	LED, SLR-34VC5F		
SVR152	18E04325S01	Semi-Variable, SVR-06T3B223			LD209	48E04216S01	LED, SLR-34VC5F		
SVR153	18E04325S01	Semi-Variable, SVR-06T3B223			LD210	48E04216S01	LED, SLR-34VC5F		
SVR171	18E04325S01	Semi-Variable, SVR-06T3B223							

Symbol No.	Part No.	Description		
LD211	48E04216S01	LED, SLR-34VC5F		
LD212	48E04216S01	LED, SLR-34VC5F		
LD213	48E04216S01	LED, SLR-34VC5F		
LD214	48E04216S01	LED, SLR-34VC5F		
LD215	48E04216S01	LED, SLR-34VC5F		
LD216	48E04216S01	LED, SLR-34VC5F		
LD217	48E04216S01	LED, SLR-34VC5F		

Coil/Switches

L201	24E04242S01	Inductor, 100 μ H		
SW201	40E04281S01	Switch Tact, SKHHAP		
SW202	40E04281S01	Switch Tact, SKHHAP		
SW203	40E04281S01	Switch Tact, SKHHAP		
SW204	40E04281S01	Switch Tact, SKHHAP		
SW205	40E04281S01	Switch Tact, SKHHAP		
SW206	40E04281S01	Switch Tact, SKHHAP		
SW207	40E04281S01	Switch Tact, SKHHAP		
SW208	40E04281S01	Switch Tact, SKHHAP		
SW209	40E04281S01	Switch Tact, SKHHAP		
SW210	40E04281S01	Switch Tact, SKHHAP		
SW211	40E04281S01	Switch Tact, SKHHAP		
SW212	40E04281S01	Switch Tact, SKHHAP		
SW213	40E04281S01	Switch Tact, SKHHAP		
SW214	40E04281S01	Switch Tact, SKHHAP		
SW215	40E04281S01	Switch Tact, SKHHAP		
SW216	40E04281S01	Switch Tact, SKHHAP		
SW217	40E04281S01	Switch Tact, SKHHAP		
SW218	40E04280S01	Switch Tact, SKHHAM		
SW219	40E04280S01	Switch Tact, SKHHAM		
SW220	40E04280S01	Switch Tact, SKHHAM		
SW221	40E04280S01	Switch Tact, SKHHAM		
SW222	40E04281S01	Switch Tact, SKHHAP		
SW223	40E04281S01	Switch Tact, SKHHAP		
SW224	40E04281S01	Switch Tact, SKHHAP		
SW225	40E04281S01	Switch Tact, SKHHAP		
SW226	40E04281S01	Switch Tact, SKHHAP		
SW227	40E04281S01	Switch Tact, SKHHAP		
SW228	40E04281S01	Switch Tact, SKHHAP		
SW229	40E04281S01	Switch Tact, SKHHAP		
SW230	40E04281S01	Switch Tact, SKHHAP		
SW231	40E04281S01	Switch Tact, SKHHAP		
SW232	40E04281S01	Switch Tact, SKHHAP		

Capacitors/Crystal

C201	23E04336S05	ELY., 4.7 μ F/25V		
C202	23E04334S03	ELY., 47 μ F/10V		
C203	21E04369S01	CER., 0.022 μ F		
C204	23E04338S01	ELY., 0.1 μ F/50V		
C205	21E04357S01	CER., 27pF		

Symbol No.	Part No.	Description		
C206	21E04357S01	CER., 27pF		
C207	21E04369S01	CER., 0.022 μ F		
C208	23E04334S02	ELY., 220 μ F/10V		
X201	48E04268S01	Crystal, Quarts Oscillator Unit HC18/ U7.2MHz		

Resistor

RV201	01E04375S01	Remote Signal Receiving Unit, BX-1407		
-------	-------------	---------------------------------------------	--	--

MC IND P. C. Board

LED

LD218	48E04216S01	LED, SLR-34VC5F		
-------	-------------	-----------------	--	--

Back Up P. C. Board

Switch/Capacitor/Transistor

SW235	40E04279S01	Switch Slide, SSS212A		
C235	23E04332S01	CAP., ELY., 2200 μ F/5.5V		
Q235	48E04183S01	TR., 2SC2785-F, E-RT		

Video P. C. Board

IC's/Transistors

IC251	51E04227S01	LC4066B		
IC252	51E04227S01	LC4066B		
Q251	48E04179S01	2SC1815		
Q252	48E04169S01	2SA1015		
Q253	48E04179S01	2SC1815		
Q254	48E04169S01	2SA1015		
Q255	48E04179S01	2SC1815		
Q256	48E04169S01	2SA1015		

Capacitors

C251	23E04335S02	ELY., 100 μ F/16V		
C252	23E04335S02	ELY., 100 μ F/16V		
C253	23E04335S02	ELY., 100 μ F/16V		
C254	23E04334S04	ELY., 47 μ F/10V		
C255	23E04335S05	ELY., 470 μ F/16V		

Symbol No.	Part No.	Description			Symbol No.	Part No.	Description		
C256	23E04334S05	ELY., 470 μ F/10V			Miscellaneous				
C257	21E04353S02	CER., 12pF			FU801	65E04422S01	Fuse Fu-621034-326		
C258	23E04334S05	ELY., 470 μ F/10V			T801	25E04421S01	Power Transformer NPT-23845		
C259	21E04353S02	CER., 12pF			P1	30E04373S01	AC Power Cord		
C260	23E04334S05	ELY., 470 μ F/10V			FL201	65E04282S01	Fluorescence Lamp 6MT-99GK		
C261	21E04353S02	CER., 12pF			PL301	65E04284S01	Lamp, PL-12350023E		
Jacks					J1	09E04291S01	AC Outlet		
RJ251	09E04419S01	RCA 3P, T6125-BAAA			J2	09E04291S01	AC Outlet		
RJ252	09E04419S01	RCA 3P, T6125-BAAA			J3	09E04291S01	AC Outlet		
Tuner Switch P. C. Board									
Switch									
SW236	40E04416S01	Push Switch, SW-1301204							
Capacitor P. C. Board									
Capacitors/PTC									
C801	23E04427S01	ELY., 10000 μ F/120V							
C802	23E04427S01	ELY., 10000 μ F/120V							
C803	23E04428S01	ELY., 10000 μ F/85V							
C804	23E04428S01	ELY., 10000 μ F/85V							
PTC801	48E05106S01	RDE185A							
PTC802	48E05106S01	RDE185A							
Serial Control P. C. Board									
Jacks									
DJ491	09E04294S01	DIN 4P, CS4440-01-1111							
DJ492	09E04293S01	DIN 3P, CS4430-01-1111							
MJ491	09E04290S01	MIC, YKB21-5129							

Cabinet Assembly Parts List

Symbol No.	Index	Part No.	Description			Symbol No.	Index	Part No.	Description		
2	4-A	64E04487S01	Front Panel			42		03E04479S01	Tap Screw S, Bind Head, B (M2.6×5)		
3	3-A	01E04451S01	ASSY., Display Frame			43		03E04479S02	Tap Screw S, Bind Head, B (M3×6)		
4	3-C	01E04492S01	ASSY., Button Guide			44		03E04479S03	Tap Screw S, Bind Head, B (M3×8)		
5	4-C	01E04489S01	ASSY., Tact Guide			45	1-D	03E04479S02	Tap Screw S, Bind Head, B (M3×6)		
6	4-C	01E04488S01	ASSY., Tact Guide			46		03E04480S01	Tap Screw S, Bind Head, Y (M3×6)		
7	4-C	07E04491S01	Button Guide			47		03E04479S03	Tap Screw S, Bind Head, B (M3×8)		
8	4-C	07E04447S01	Button Guide			48		03E04480S02	Tap Screw S, Bind Head, Y (M3×8)		
9	4-C	07E04448S01	Button Guide			49		03E04479S04	Tap Screw S, Bind Head, B (M3×10)		
10	3-B	07E04446S01	Button Guide			50	1-H	03E04481S01	Tap Screw S, Washer Faced, B (M3×6)		
11	3-B	07E04490S01	Button Guide			51		03E04481S02	Tap Screw S, Washer Faced, Y (M3×6)		
12	3-B	07E04449S01	Guide, Preset			52		03E04478S02	Tap Screw P, Round Head, Y (M3×8)		
13	4-C	61E04452S01	LED, Lens			53		03E04477S01	Tap Screw B, Bind Head, Y (M3×6)		
14	4-A	61E04380S02	Display Glass			54		03E04477S02	Tap Screw B, Bind Head, Y (M3×14)		
15	4-B	61E04382S01	Glass, Lamp			55		03E04477S03	Tap Screw B, Bind Head, Y (M3×20)		
16	4-D	64E04434S01	Side Cap			56	3-E	03E04483S01	Tap Screw, Washer Faced (M3×18)		
17	2-C	64E04433S01	Side Cap			57		03E04479S05	Tap Screw S, Bind Head, B (M4×8)		
18	4-B	36E04386S01	Knob Base, VR			58		03E04480S03	Tap Screw S, Bind Head, Y (M4×14)		
19		15E04435S01	Rear Panel			59	2-F	03E04482S01	Tap Screw S, Truss, Y (M4×8)		
20	2-B	15E04383S01	Cabinet			60		04E04485S01	Plain Washer, B (M8.3×5)		
21	3-E	75E04454S01	Cloth (Knob)			61		04E04494S01	Plain Washer, B (M10.4×8)		
22		75E04455S01	Cloth (Knob)			62	3-C	03E04484S01	Tap Screw, Flat Head, Y (M2.6×6)		
23		75E04453S01	Felt (Leg)			63		36A83537F01	Knob, Push Scan		
24	3-C	75E04456S01	Cloth (Knob)			64	4-B	07A80693F01	ESC, Knob Recout		
25	3-C	75E04457S01	Cloth (Knob)			65	4-B	21E04495S01	Snake Lug		
26	3-B	36E04393S01	Button, Preset			66	4-C	61A83541F01	Crystal, Timer		
27	3-D	36E04387S01	Knob, VR			67		36A67333F01	Knob, Push		
28	5-B	36E04385S01	Knob Cap, VR			68	3-C	36A80694F01	Knob, Push Recout		
29		75A67063F03	Trann-Leg			69	3-C	07E04496S01	Guide, LED		
30	3-H	14E04459S01	Shield Plate			70	3-D	36A72661F01	Knob, Push Tone		
31	4-C	14E04472S01	Shield Tube			71	3-D	36A80706F01	Knob, Rotary Tone		
32	3-C	43E04461S01	Lamp Holder								
33	1-F	46E04462S01	Stud								
34	2-B	75E04473S01	Cabinet Mat								
35	3-C	75E04464S01	FC Cushion								
36		43E04467S01	Spacer								
37		04E04466S01	Washer								
38	3-B	11E04474S01	Tape, Double Face								
39		75E04465S01	Rubber Cushion								
40	3-D	14E04471S01	Shield Cloth								
41	3-E	43E04443S01	Bush								

NOTE: The parts without part numbers are not supplied.

Symbol No.	Index	Part No.	Description			Symbol No.	Index	Part No.	Description		
72	2-E	04E04485S02	Plain Washer (M8.3×5)								
73	2-E	14E04497S01	Shield Sheet								
74	3-G	43E04502S01	Spacer								
75	1-G	07E04292S01	Fuse Holder								
76	1-G	43E04374S01	Cord Stopper								
79	1-H	09E04499S01	Ground Terminal								
80	2-H	85E04250S01	Loop Antenna								
81	6-C	03E04500S01	Screw								
82	6-C	03E04501S01	Screw								
83	1-H	29E04498S01	Short Pin								
135	4-G	77E04302S01	Front End, F019A (FE001)								

NOTE: The parts without part numbers are not supplied.

Exploded View (Cabinet)

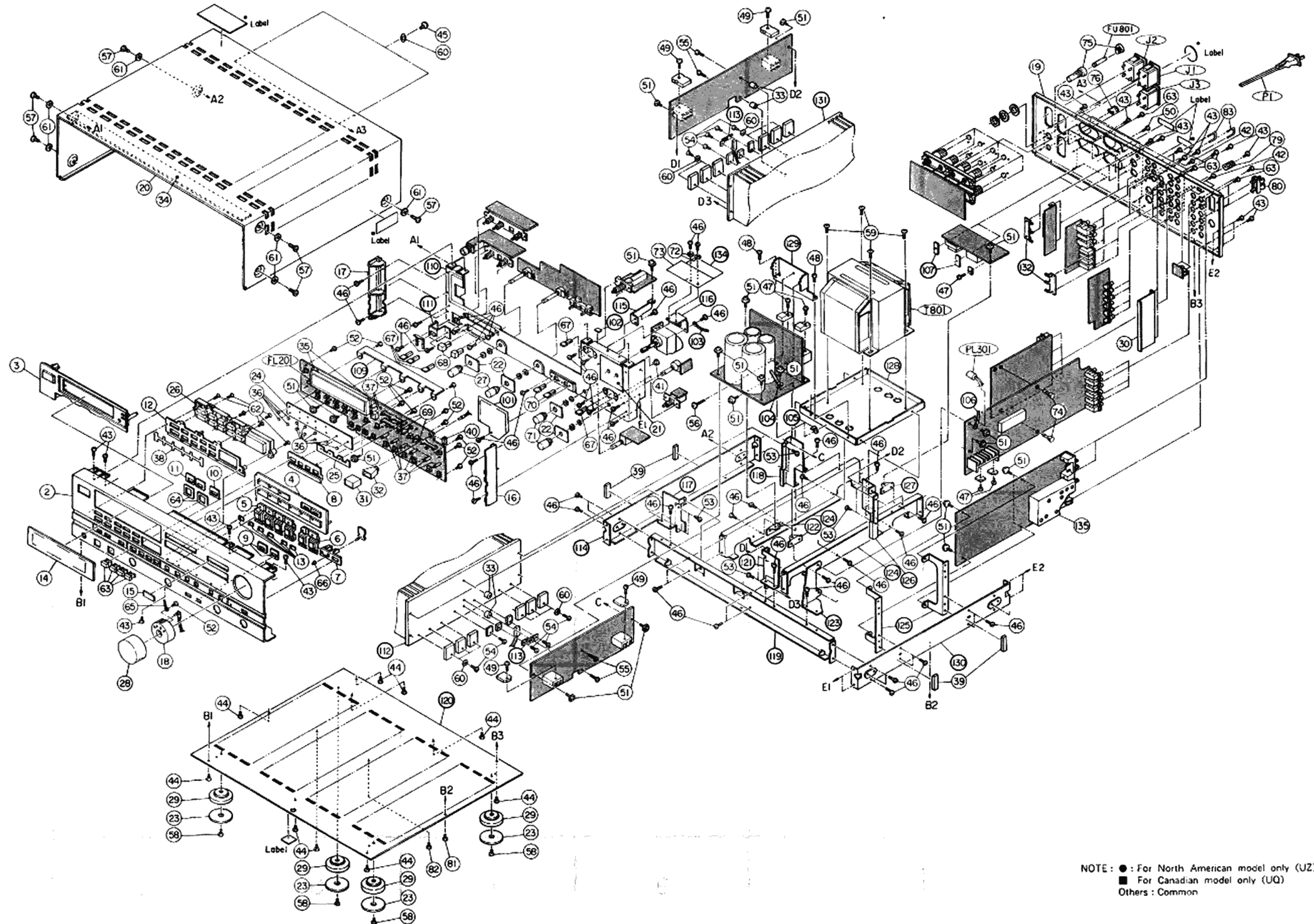

NOTE : ● : For North American model only (UZ)
 ■ : For Canadian model only (UQ)
 Others : Common

Packing Assembly Parts List

Symbol No.	Part No.	Description	Symbol No.	Part No.	Description
201	56E04398S01	Packing Pad			
202	56E04167S01	Inner Carton			
203	56E04475S01	Polyethylene Bag (Unit)			
204	56E04475S02	Polyethylene Bag (Accessories)			
205	56E04397S01	Packing Pad			
206	56E04475S03	Polyethylene Bag			
● 207	68P81880F59	Instruction Manual			
■ 207	68P81880F60	Instruction Manual			
● 208	68P44370P66	Card, Warranty			
■ 208	68P44370P63	Card, Warranty			
● 209	68R57674F01	Card, Business Reply			

Notes : ● : For North American model only (UZ), ■ : For Canadian model only (UQ), Others : Common.

Packing Method View

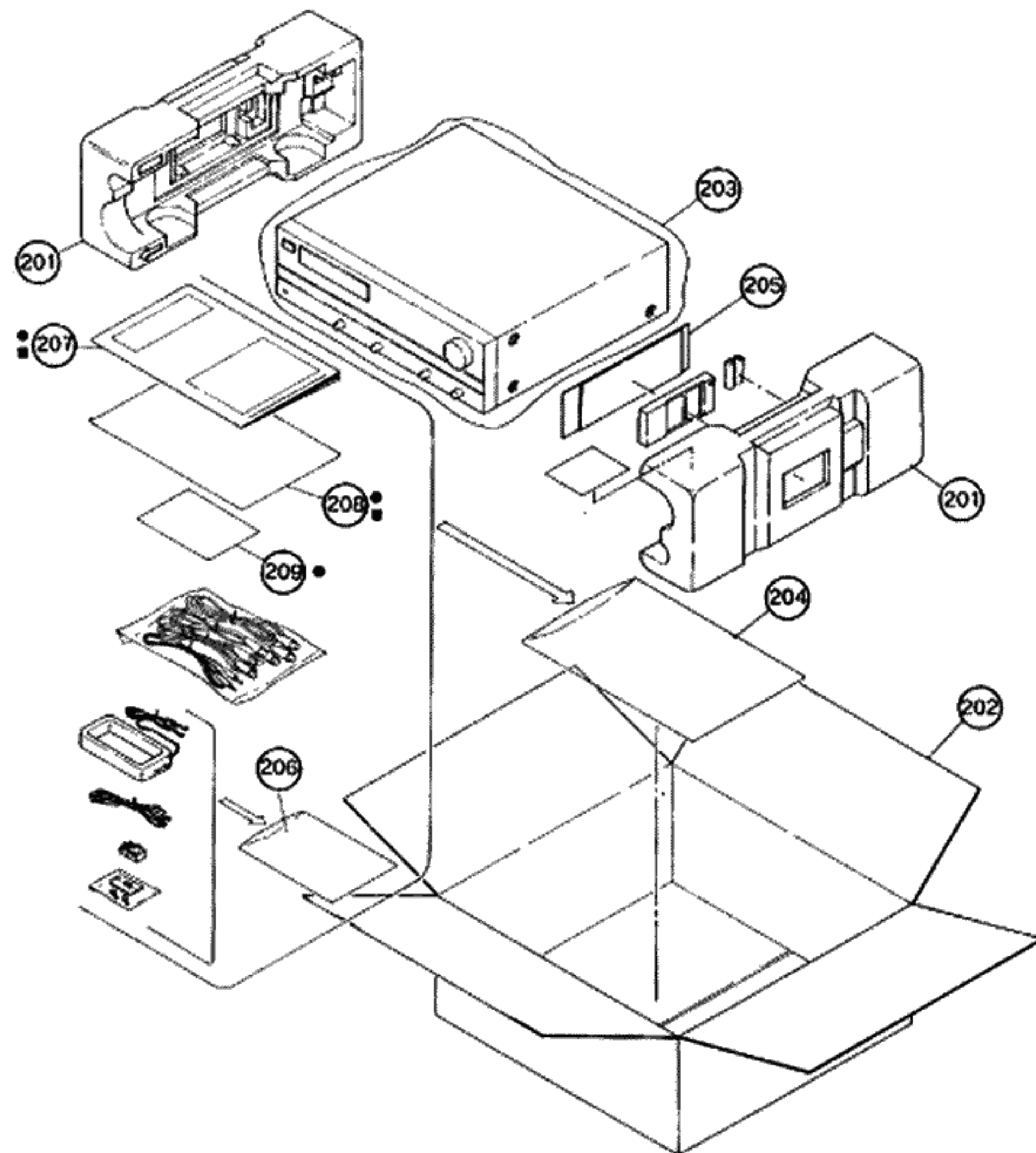

Semi-Conductor Lead Identifications

LA1222 : IC001

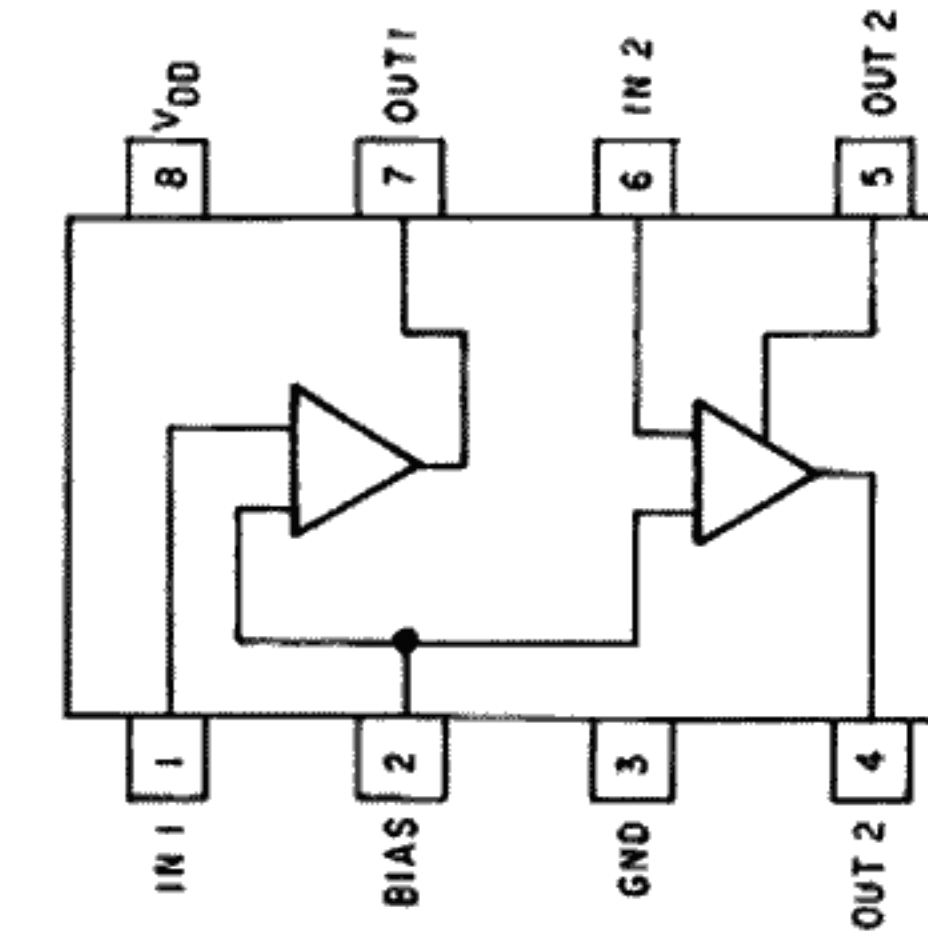
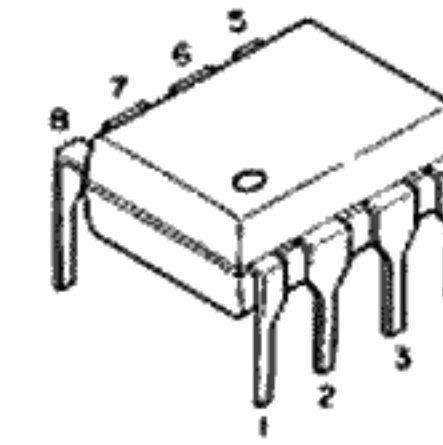

LA1235 : IC002

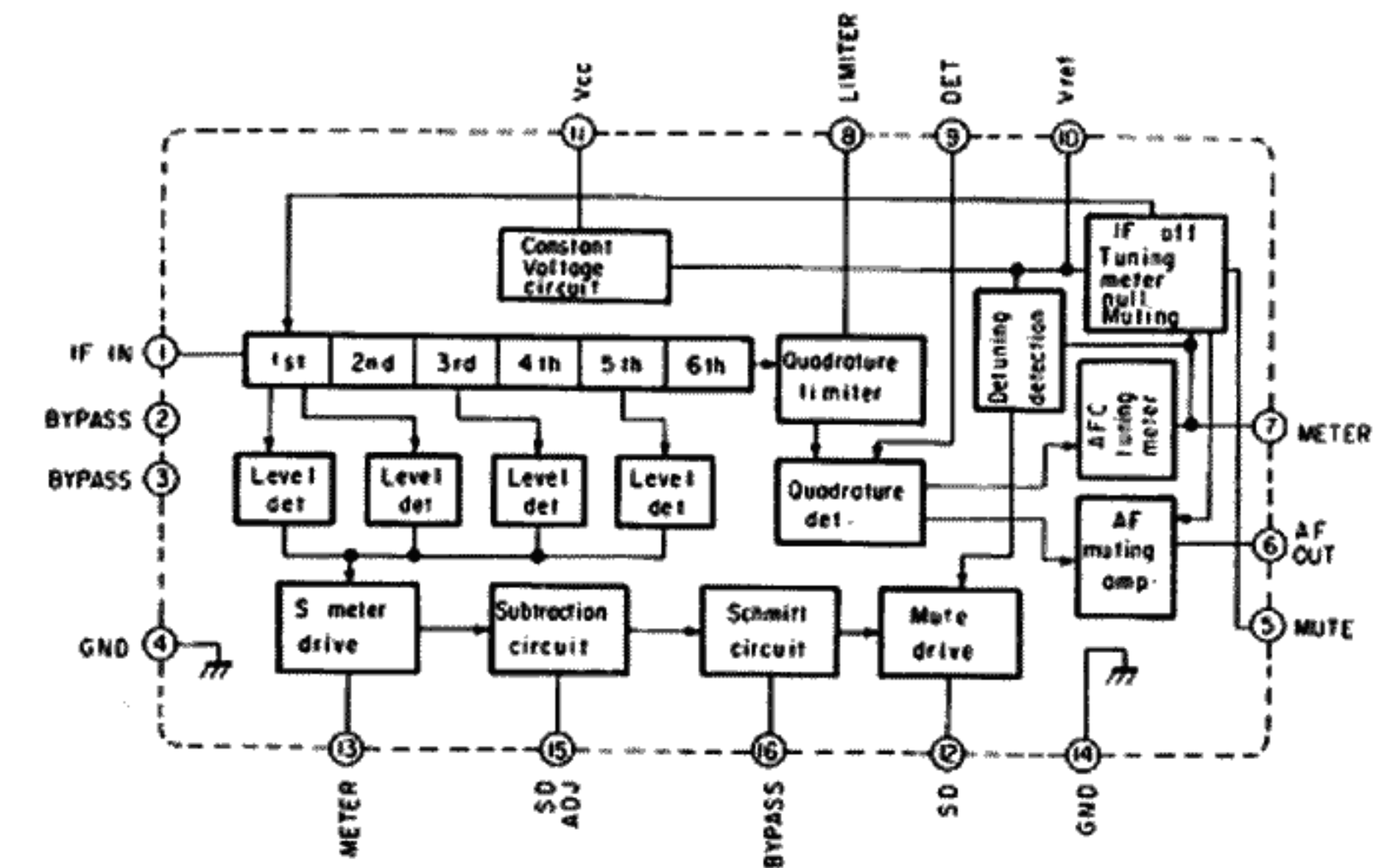
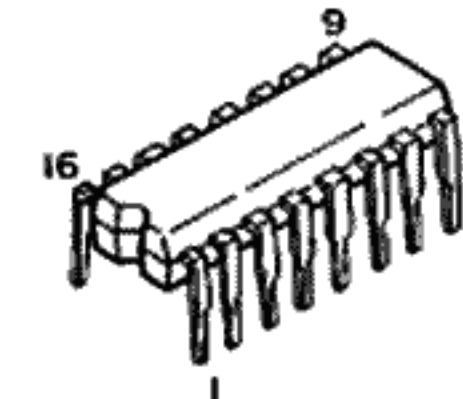

LA1245 : IC051

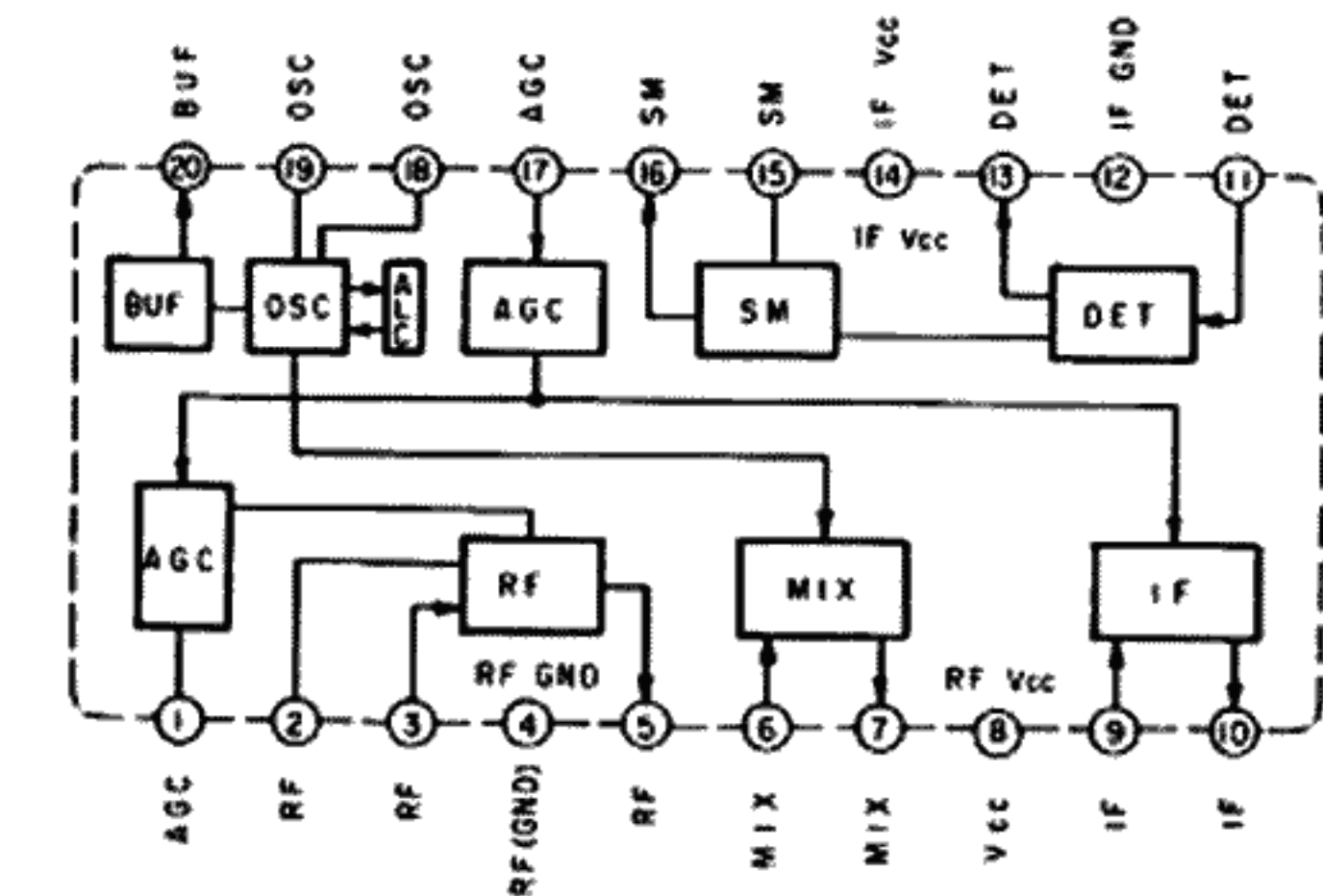
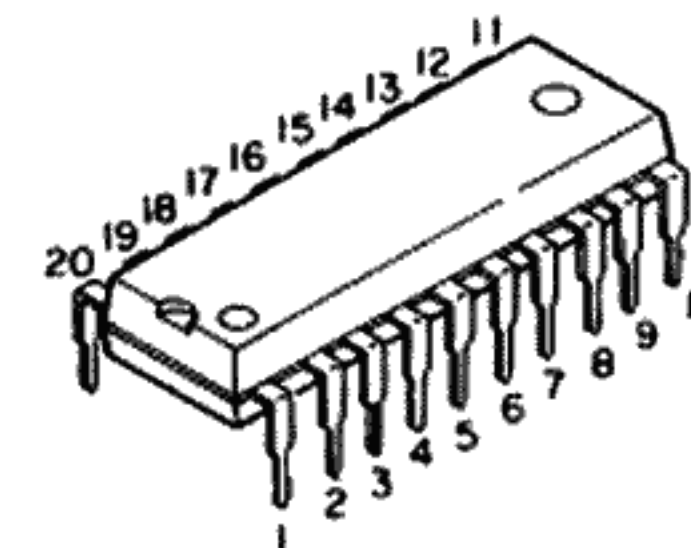

LA3401 : IC101

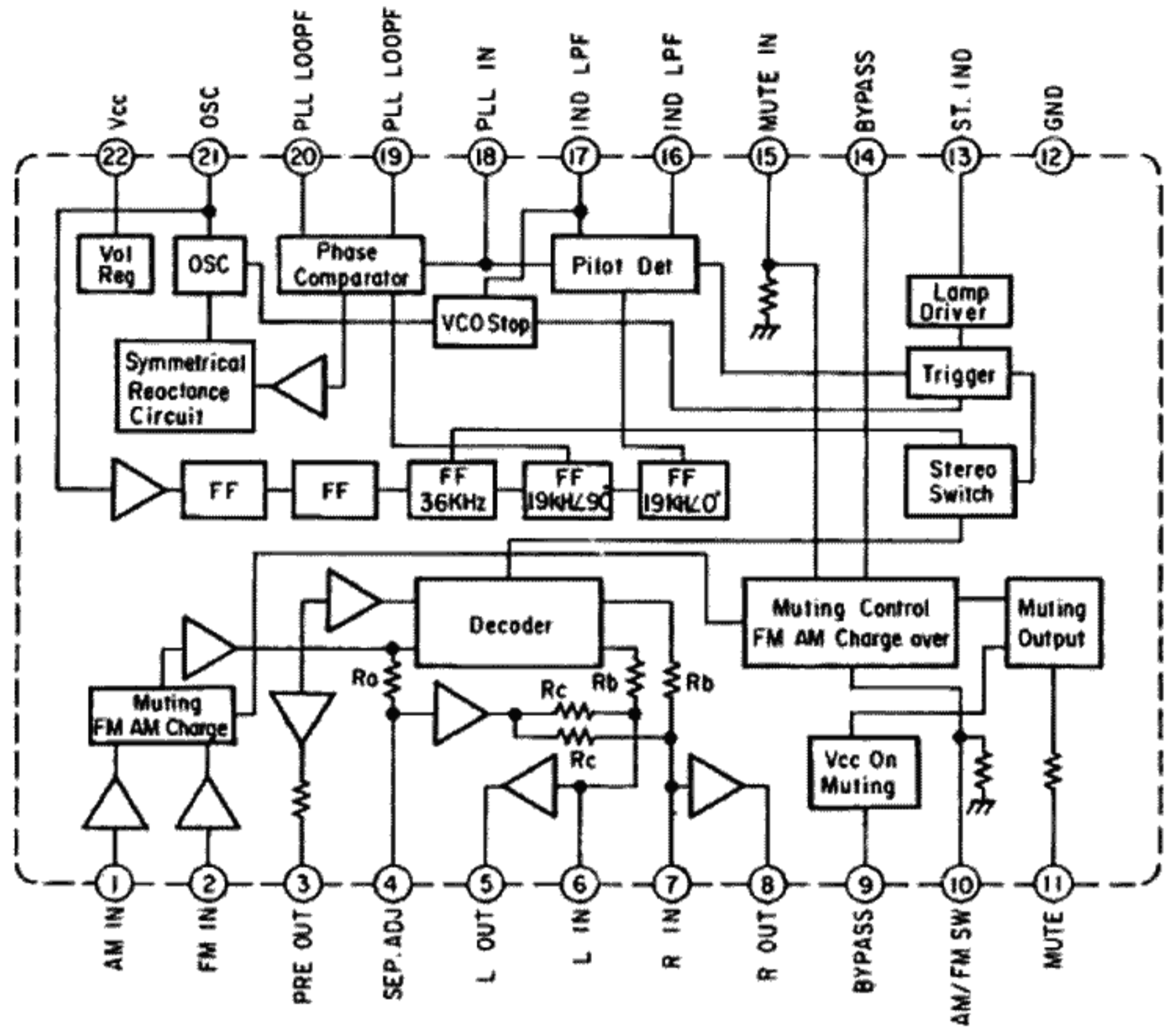
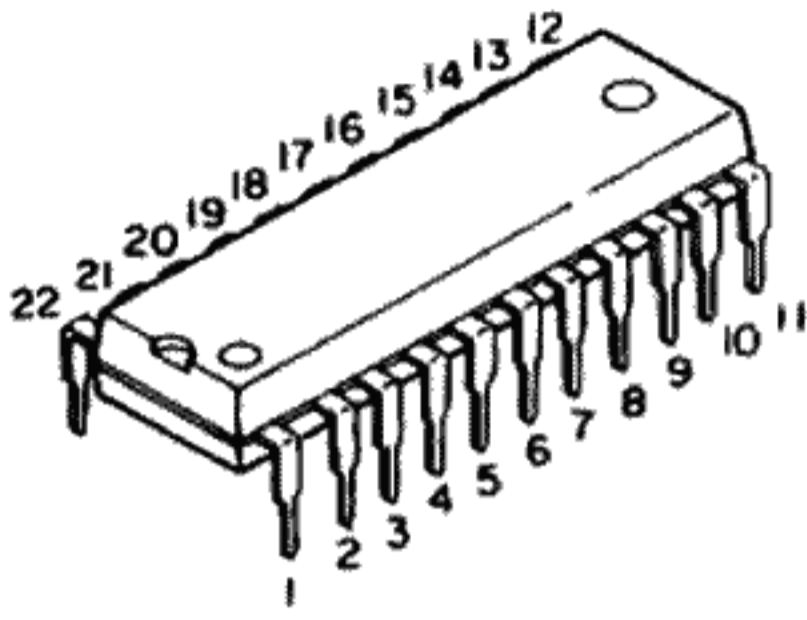

μ PC4570HA1 : IC102, 301, 402

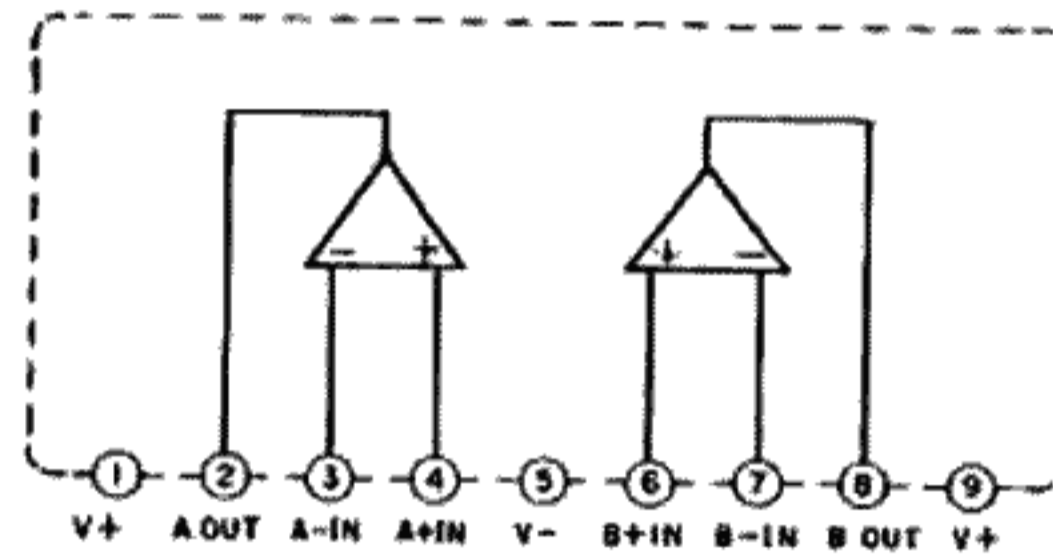
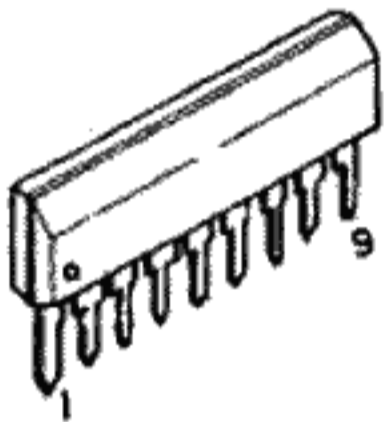

LM7000 : IC151

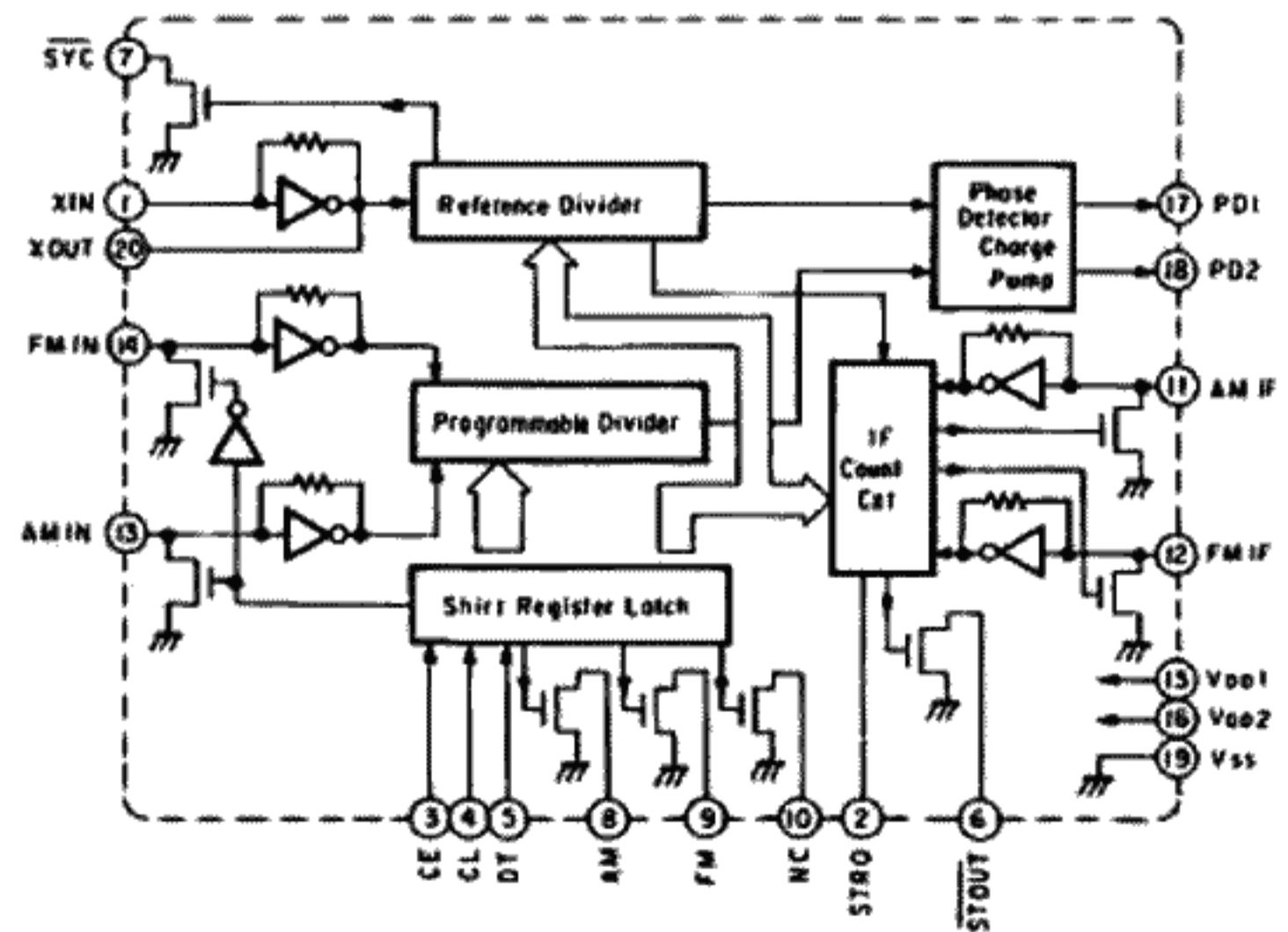
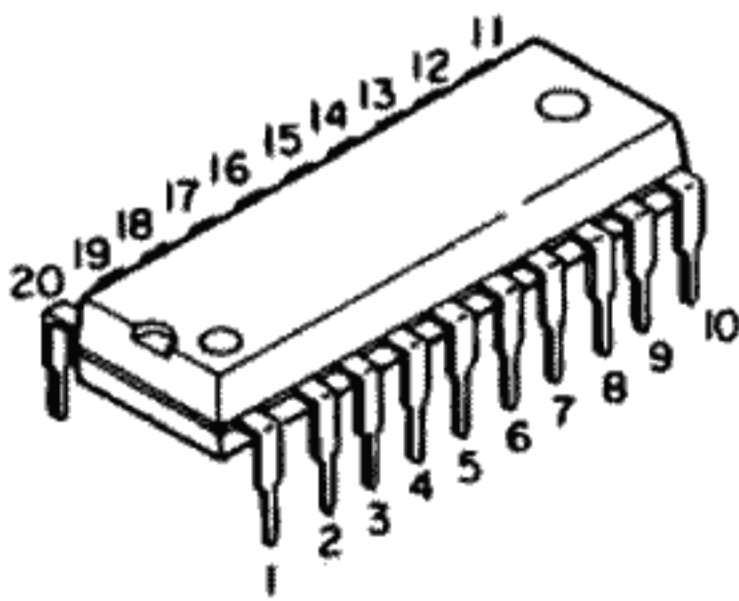

LA6458SS : IC152

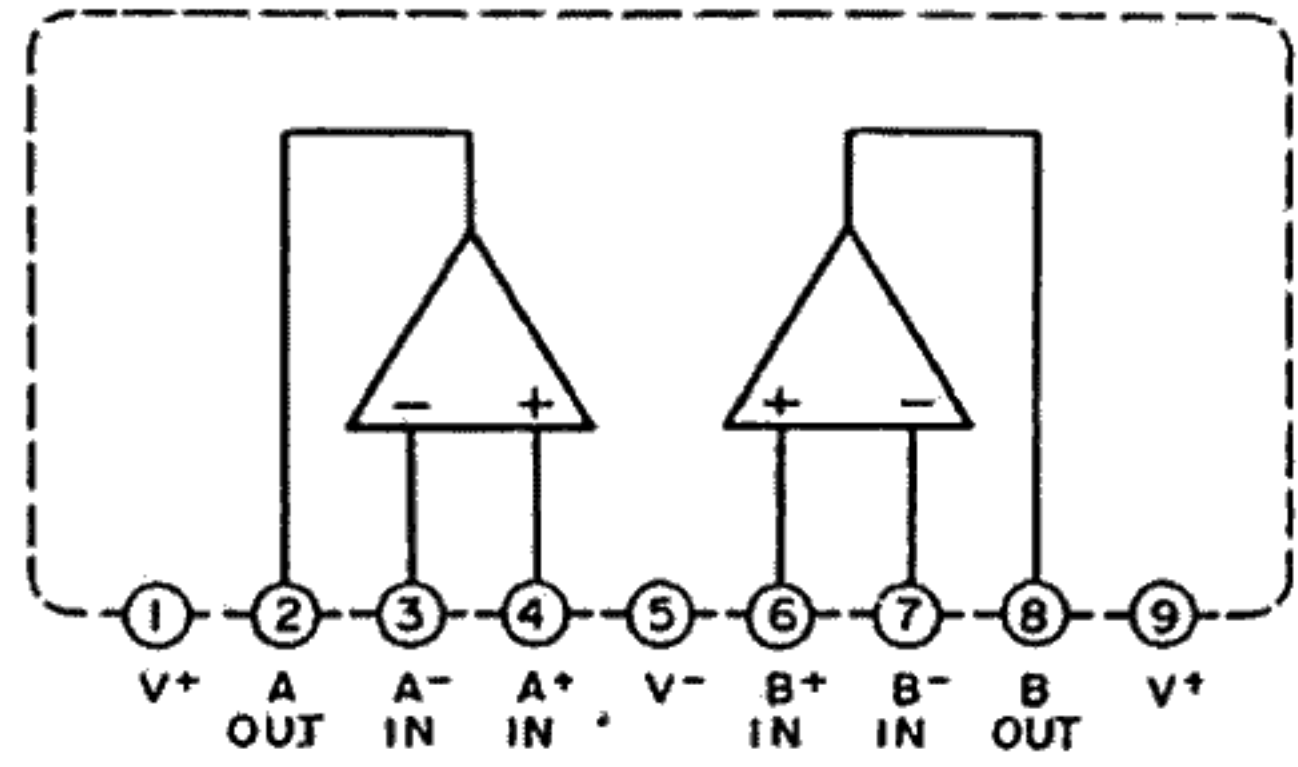
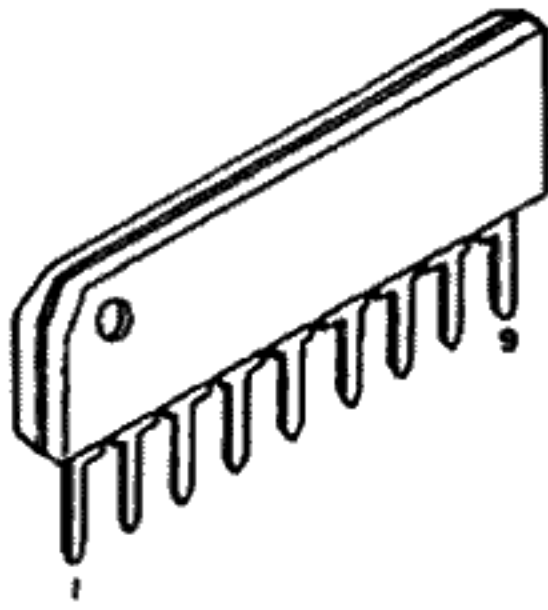

TC9301AN008 : IC201

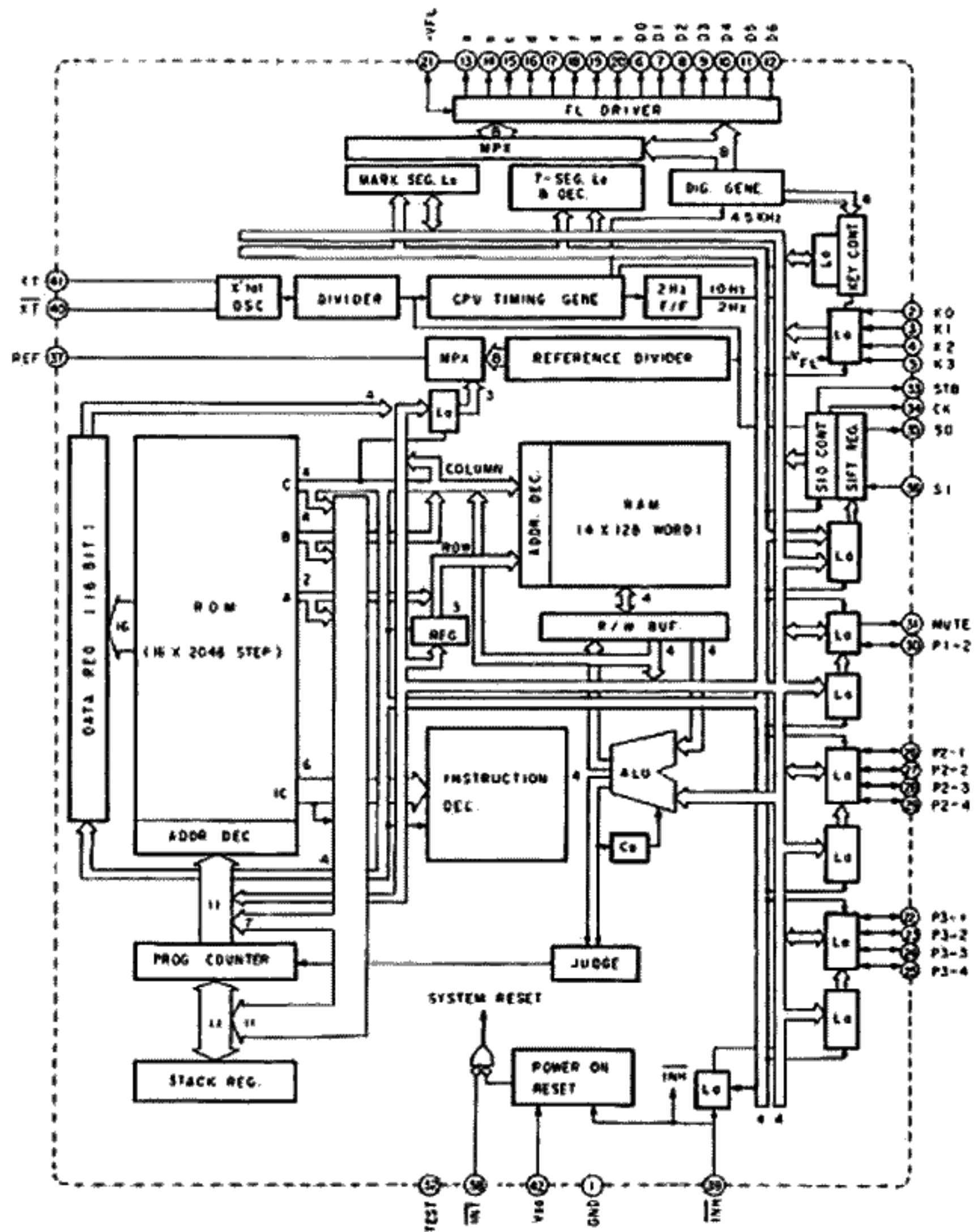
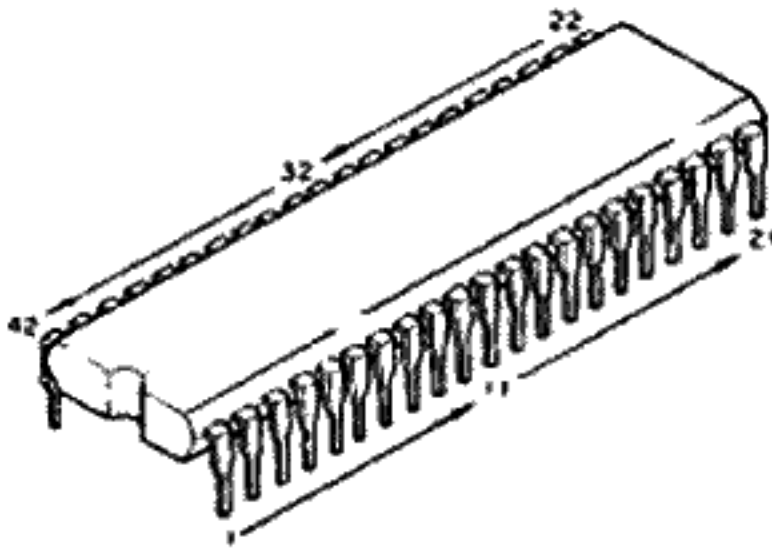

LC4066B : IC202, 251, 252

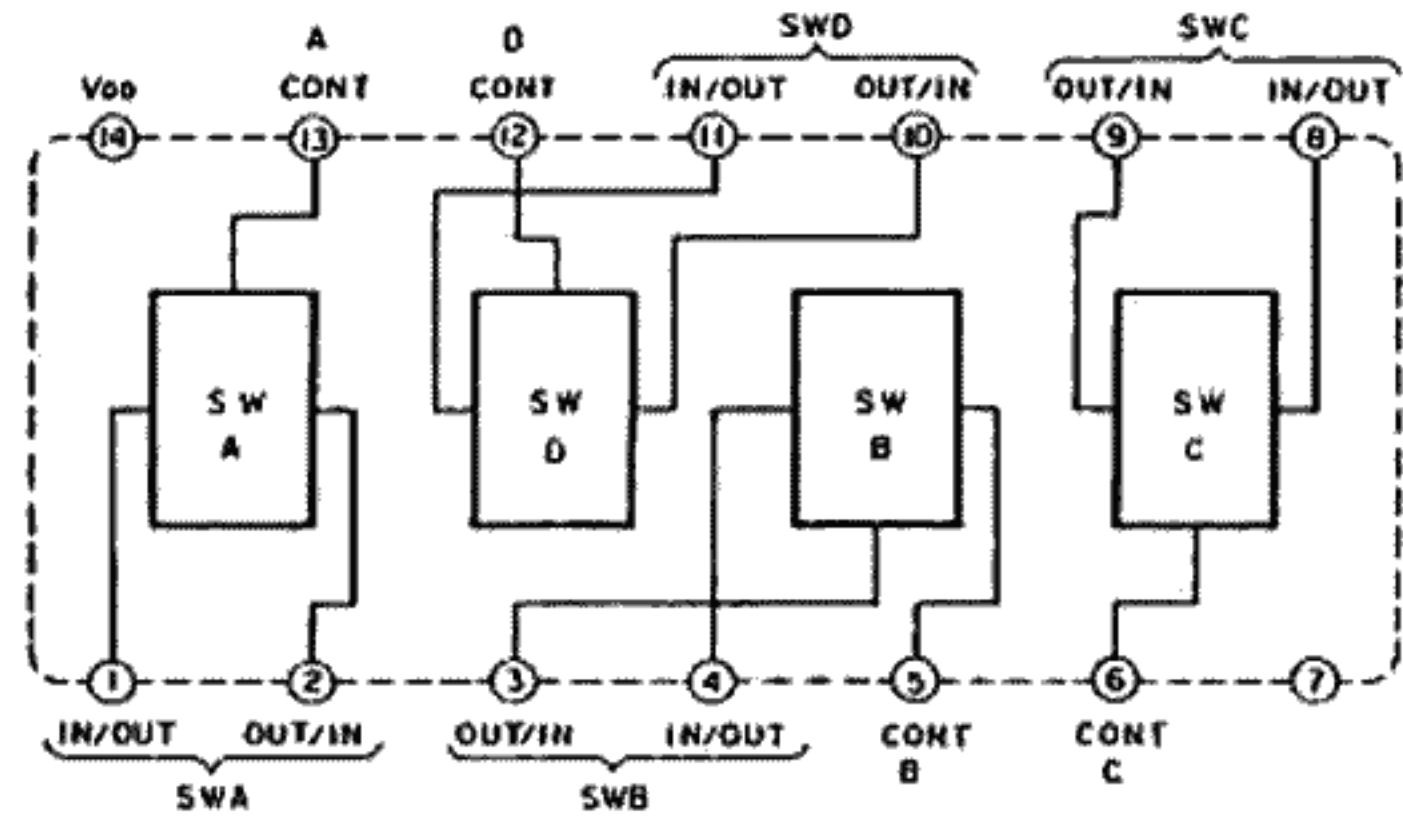
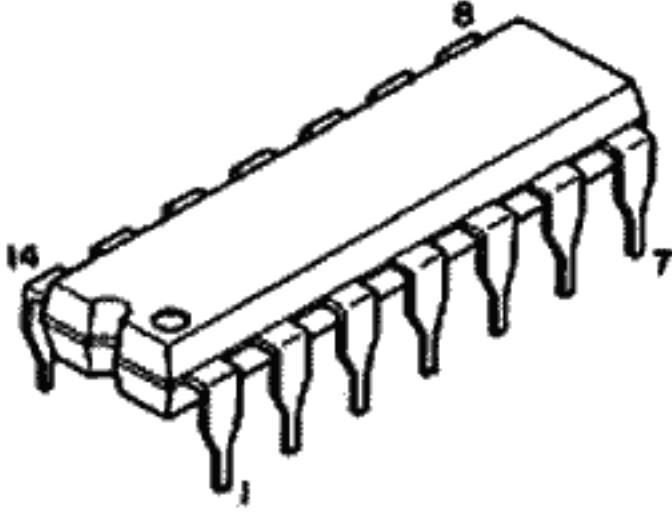

TC9173P : IC203

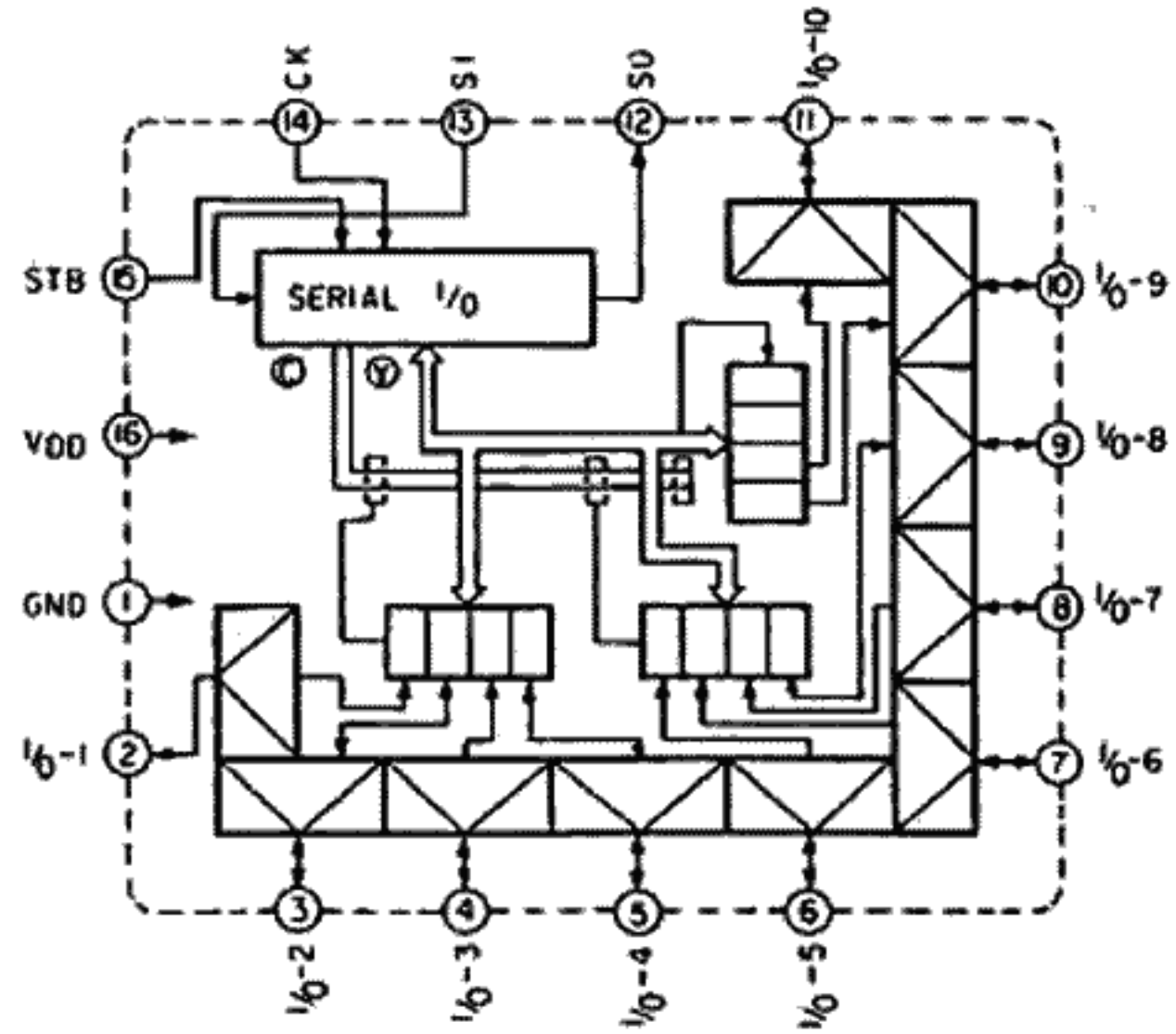
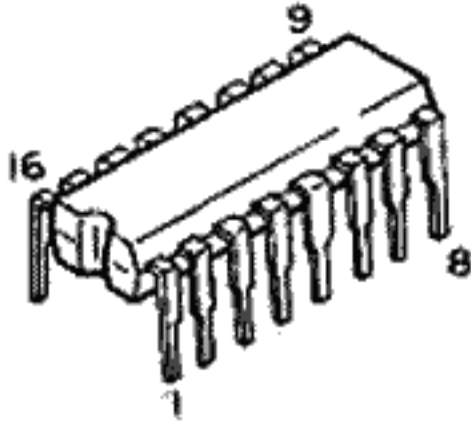

LB1423N : IC204

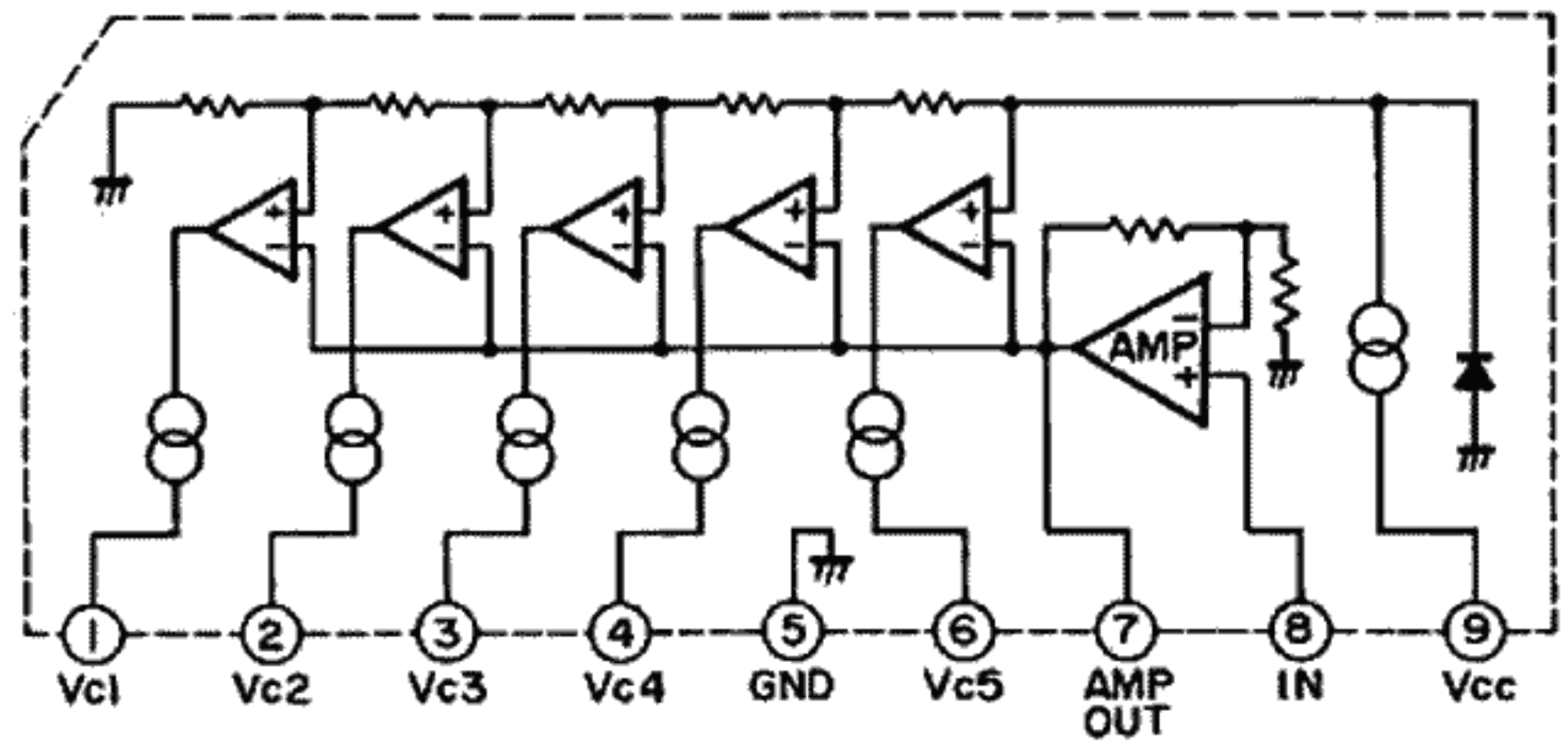
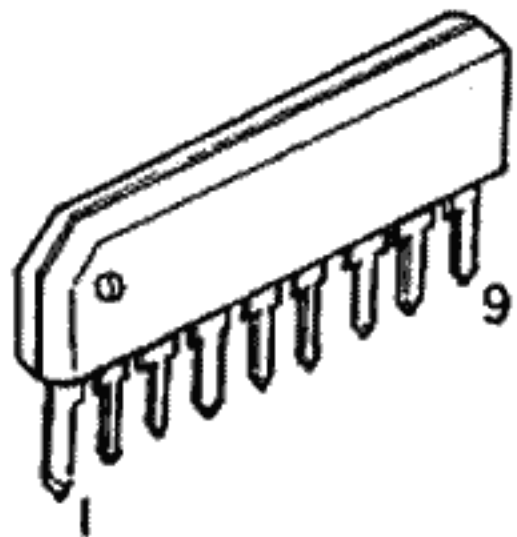

μ PD75104CW: IC302

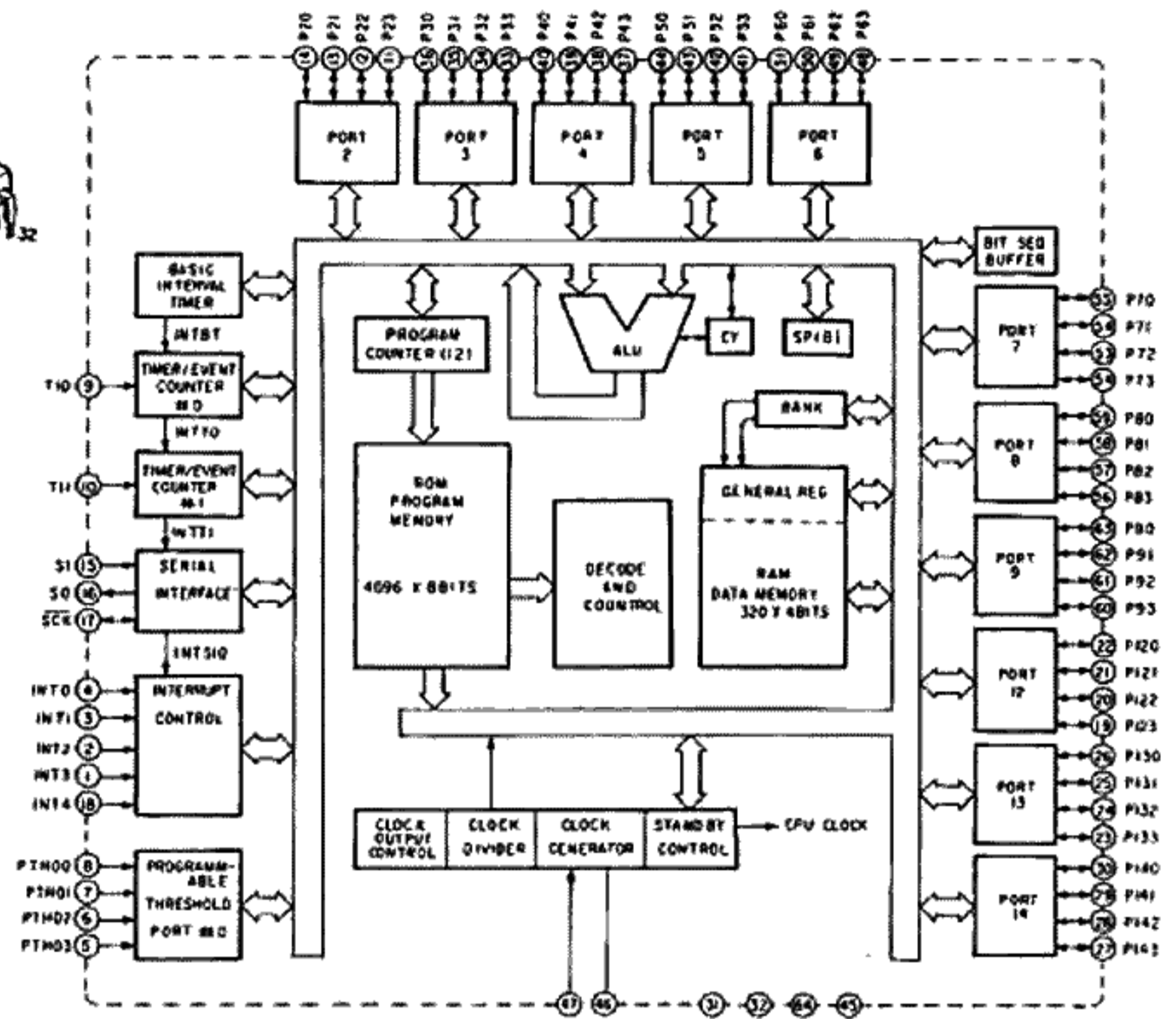
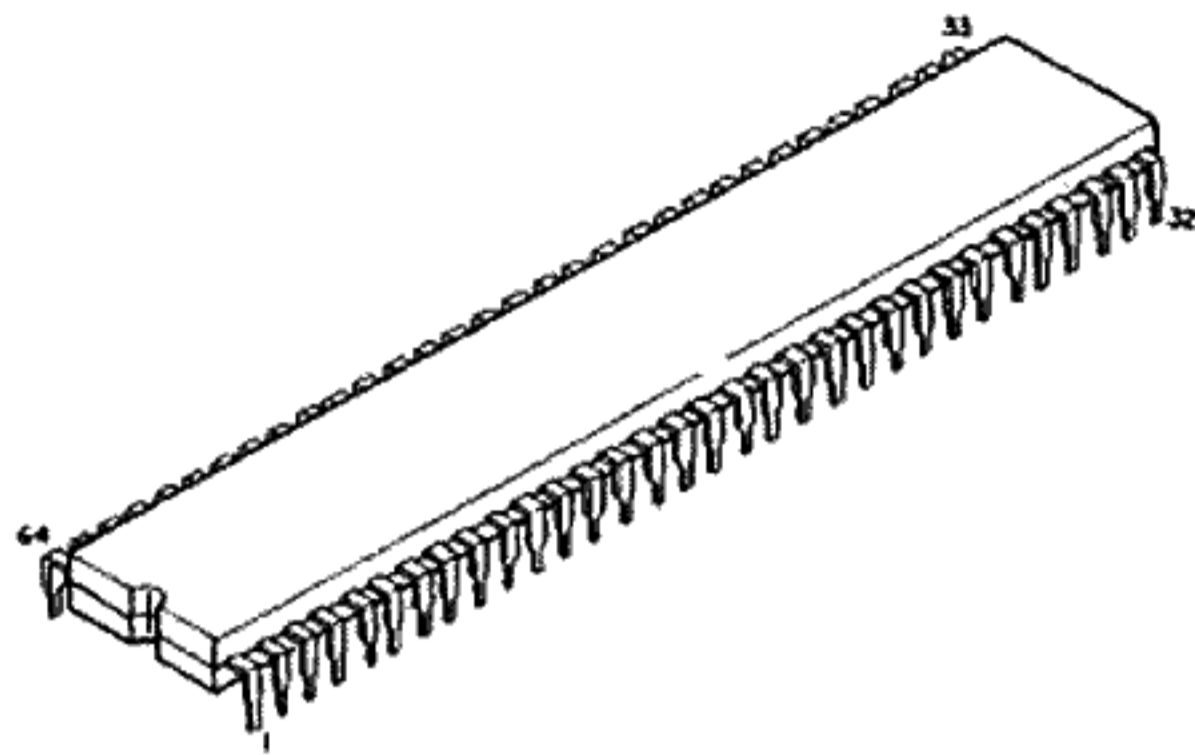

LC4001B : IC303. 311

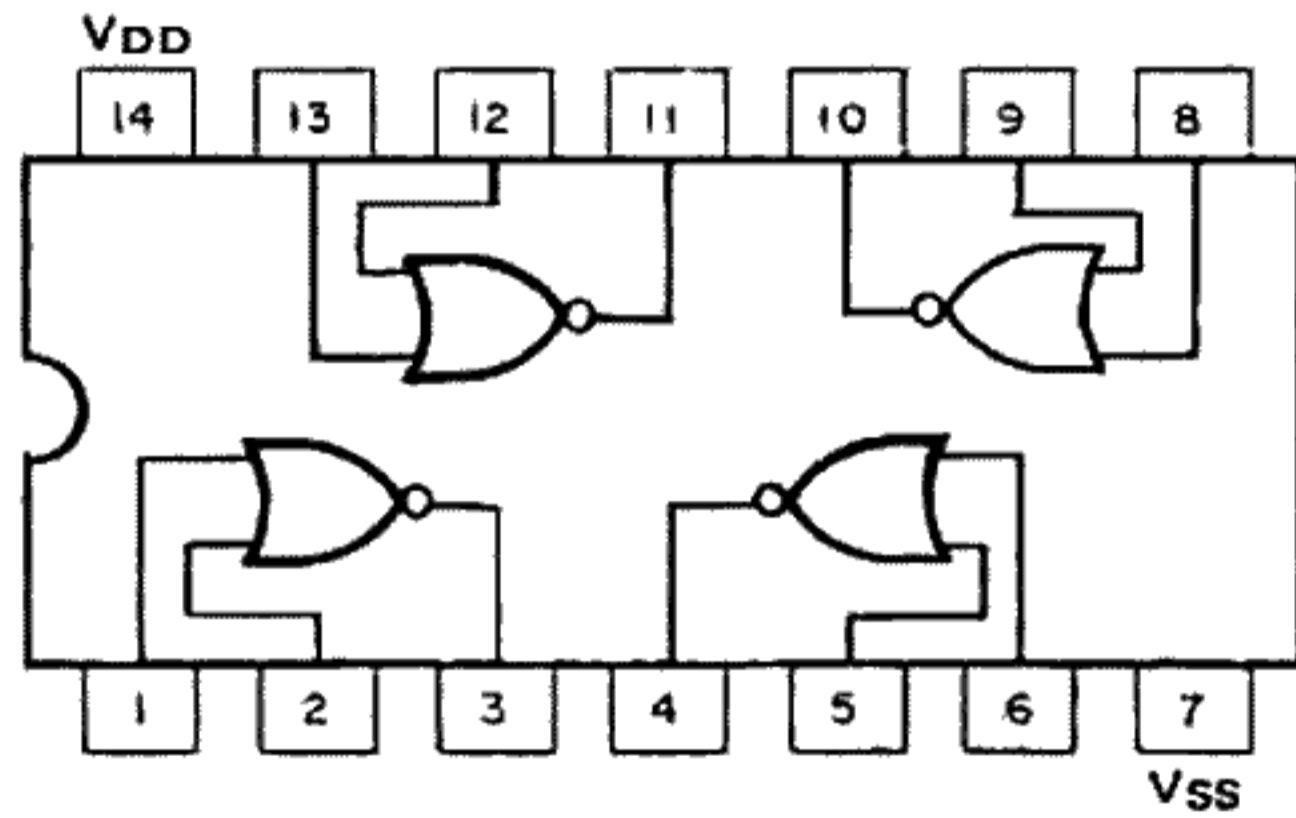
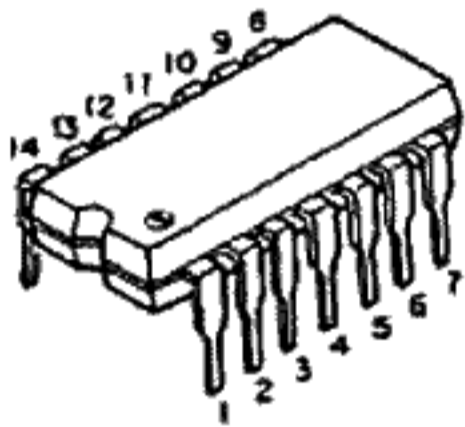

HD74145P : IC304

DN74LS145 : IC305

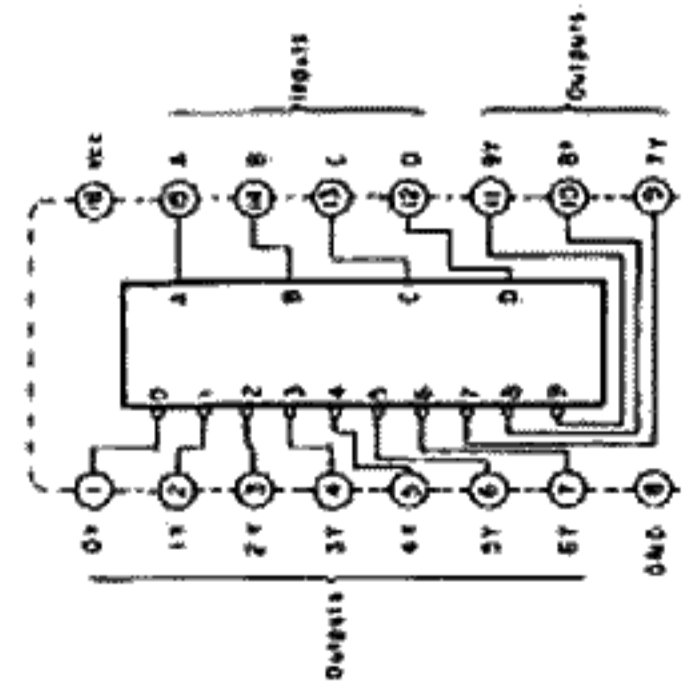
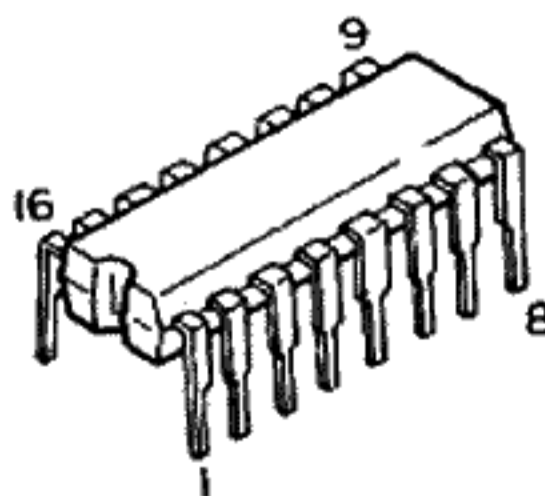

LB1645N : IC306

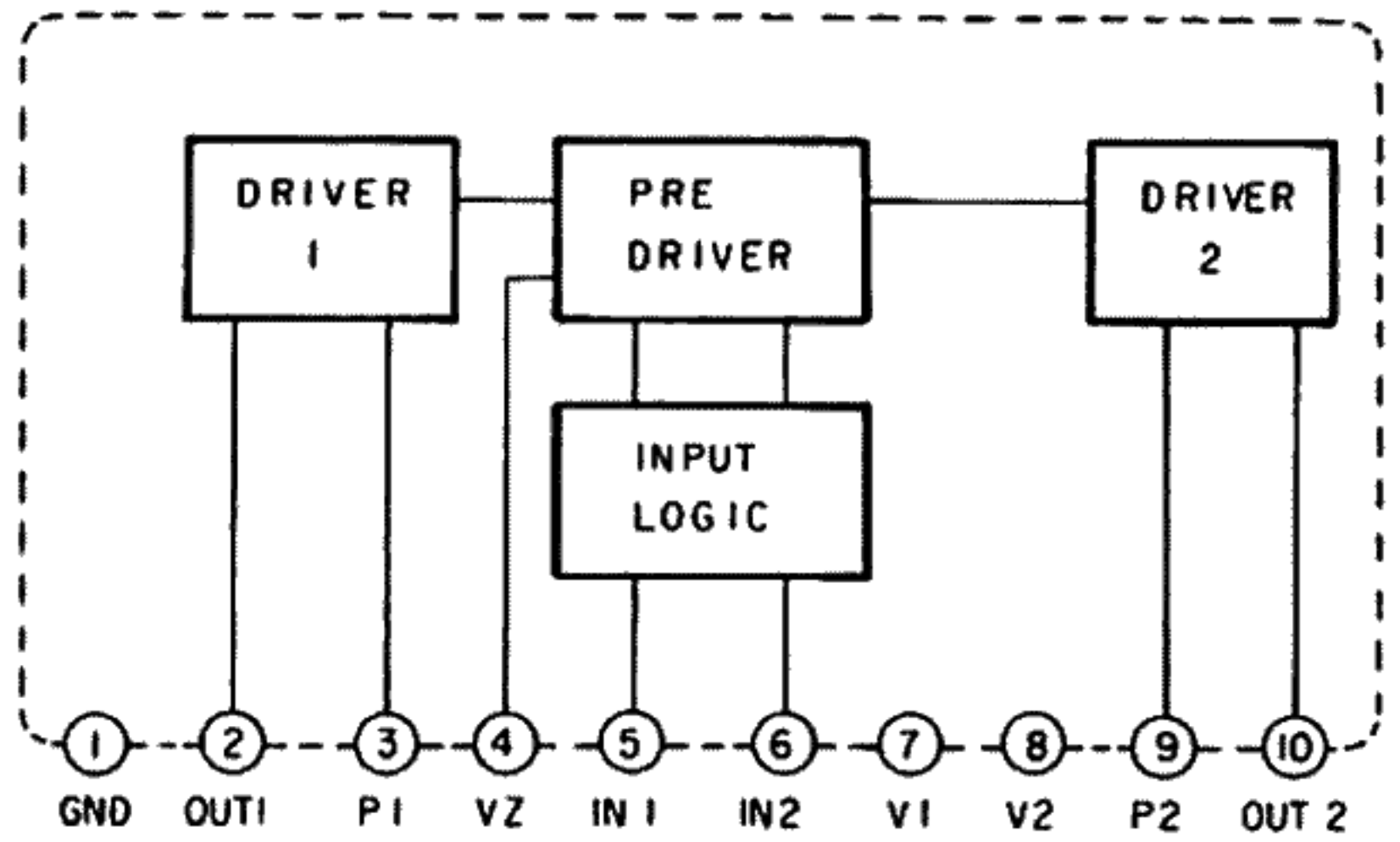
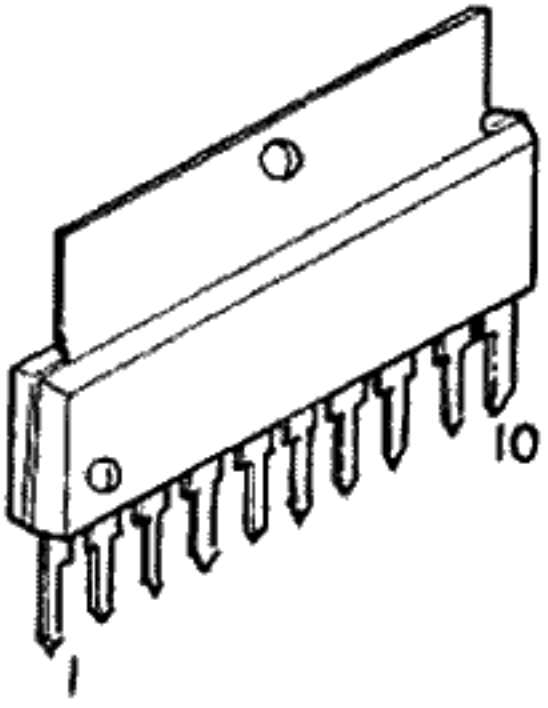

L78N05 : IC309

L78N10 : IC701

L78N12 : IC307, 308

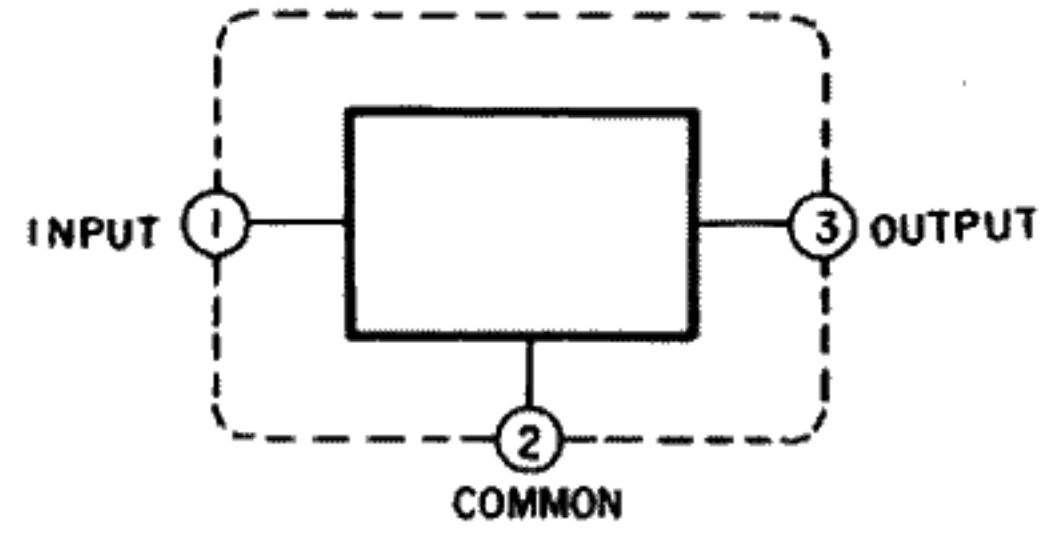
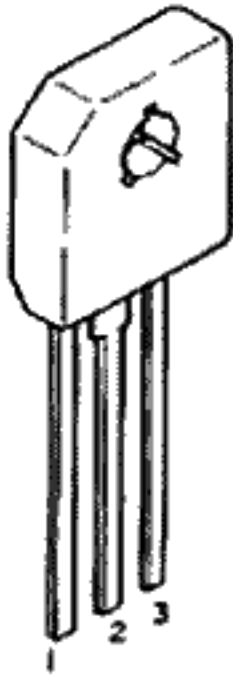

TC9163N : IC381

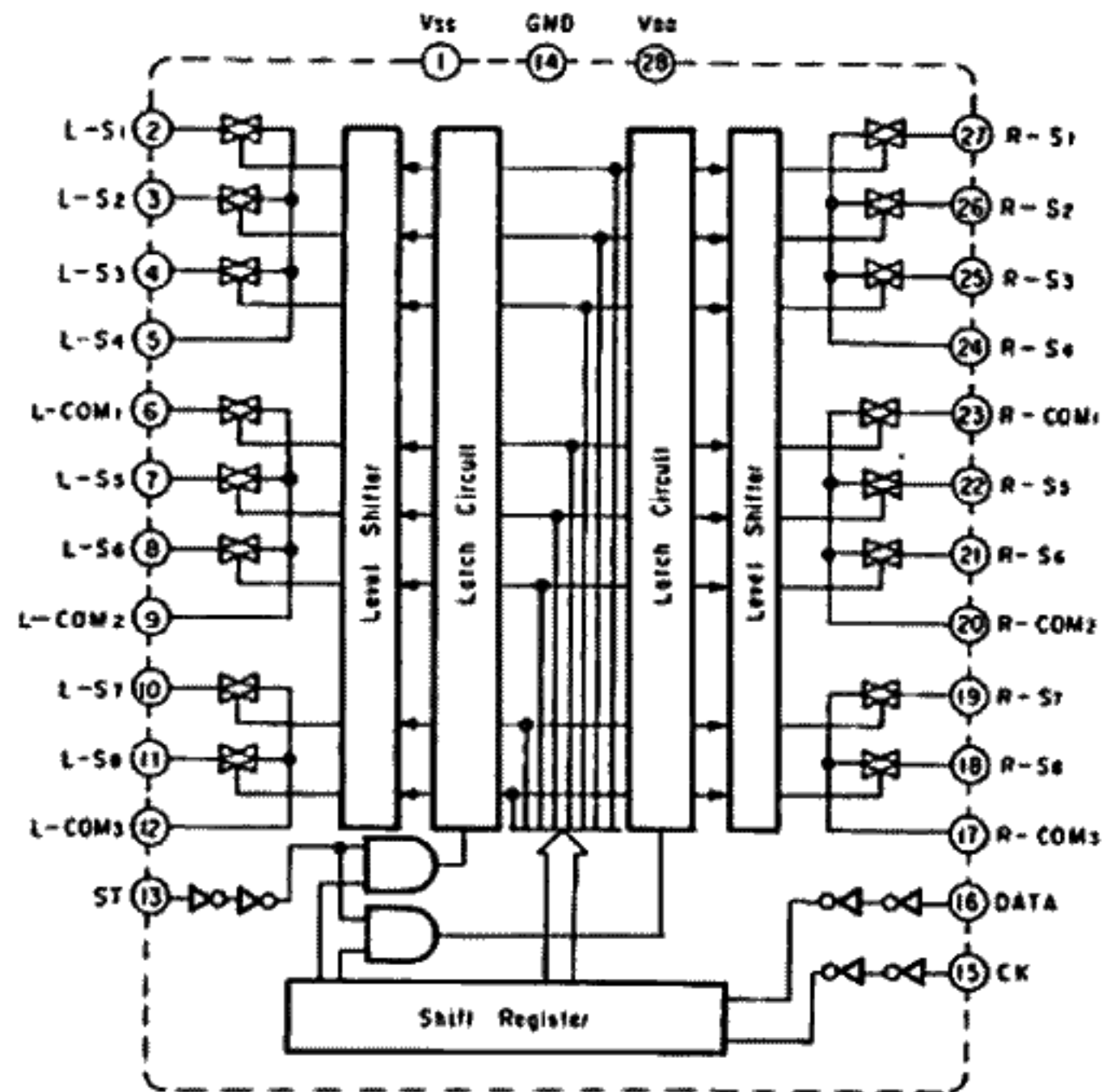
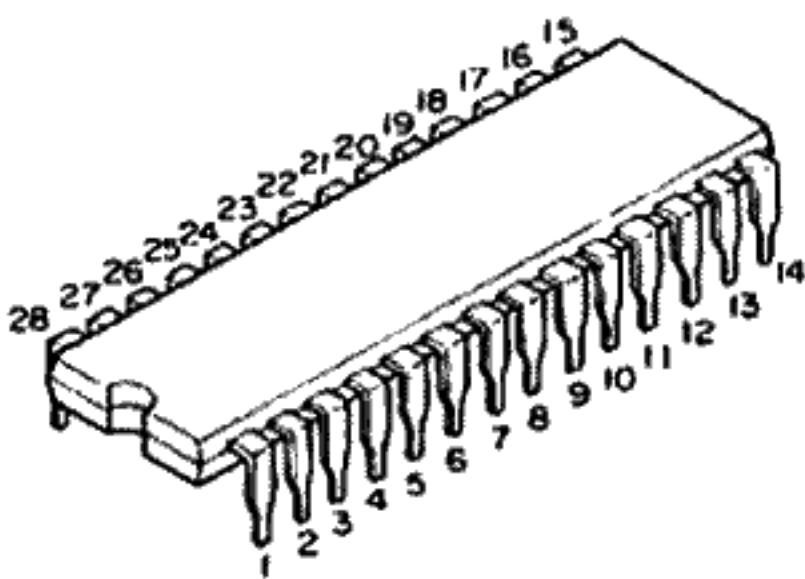

TC9164N : IC382

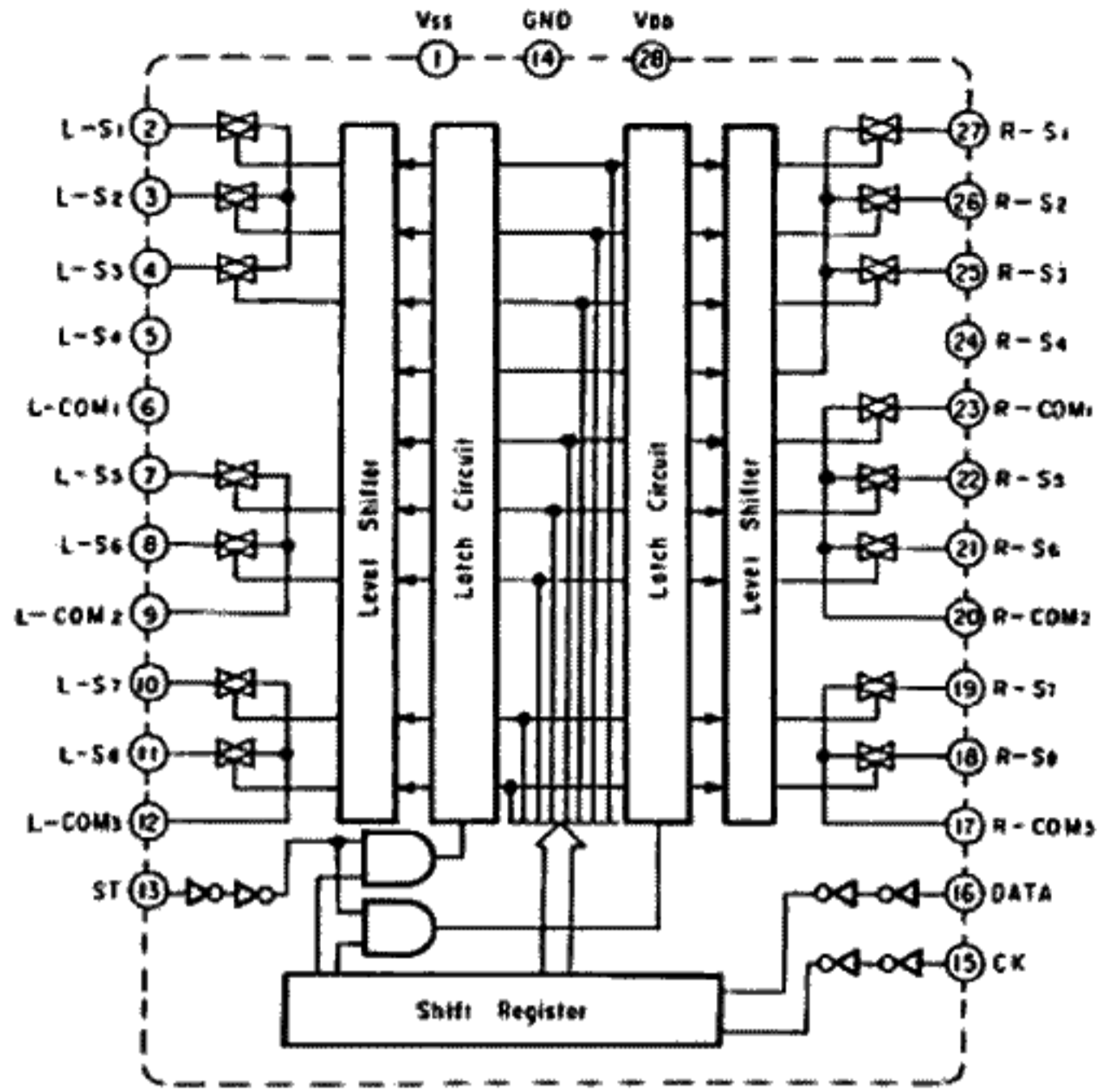
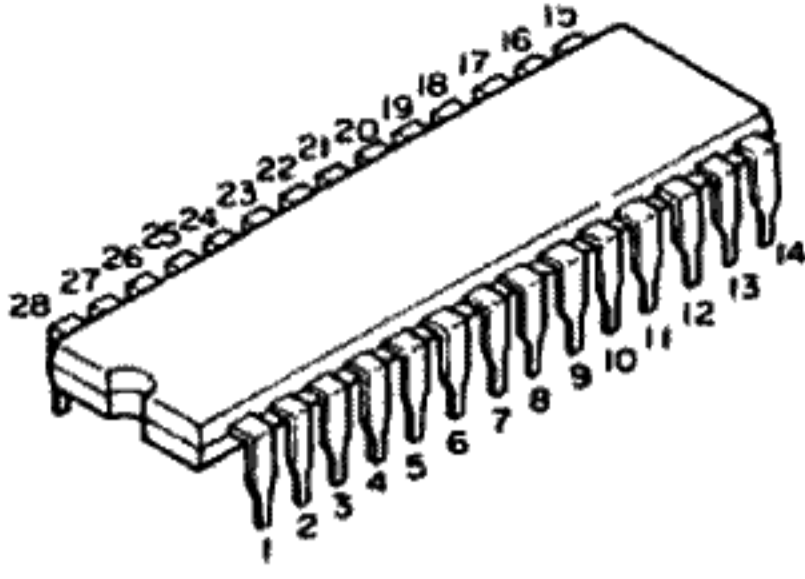

μ PC4570C1 : IC401

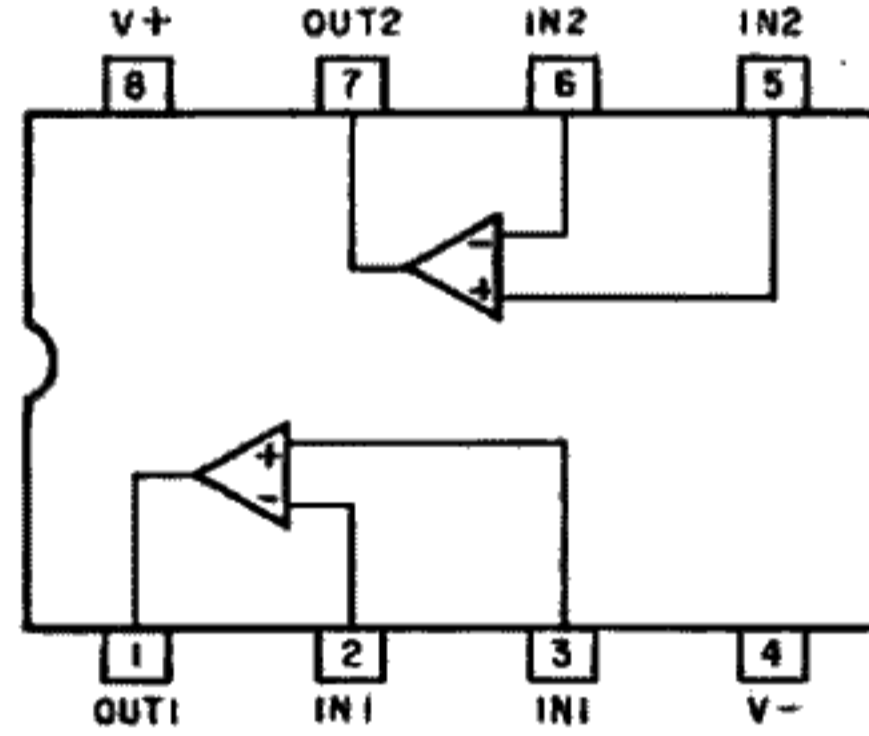
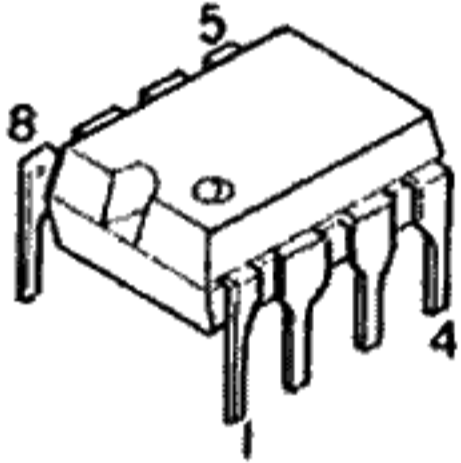

TA7317P : IC651

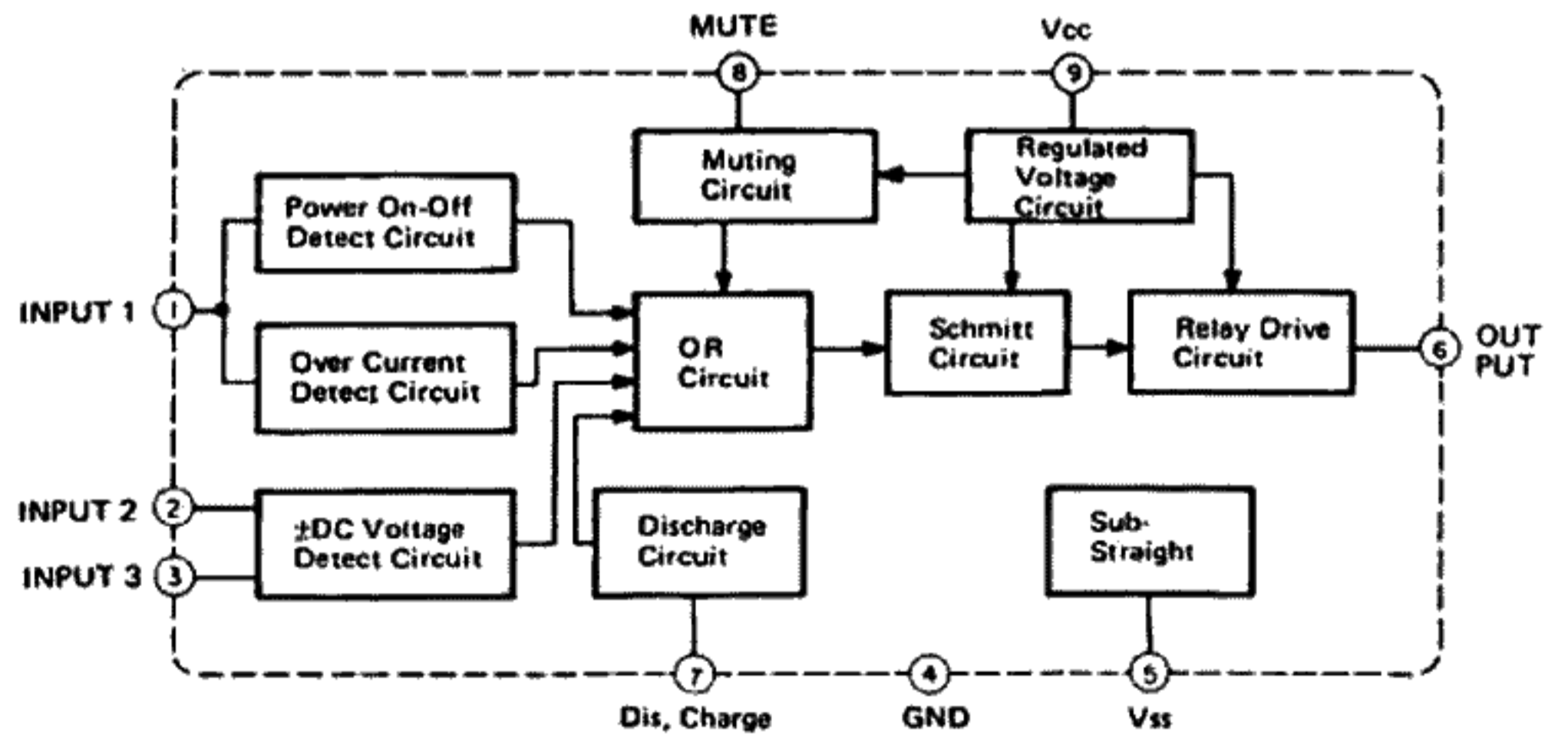
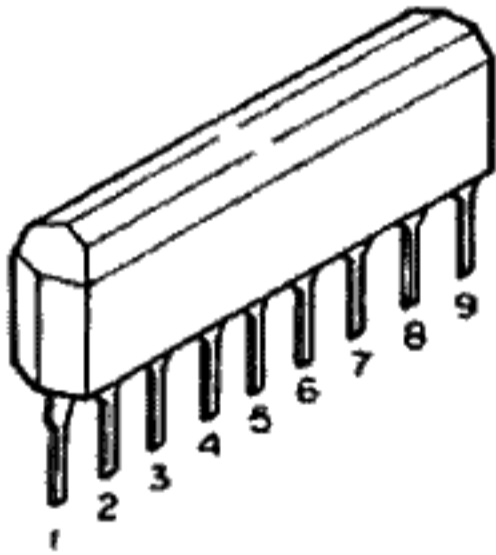

M5230L : IC702

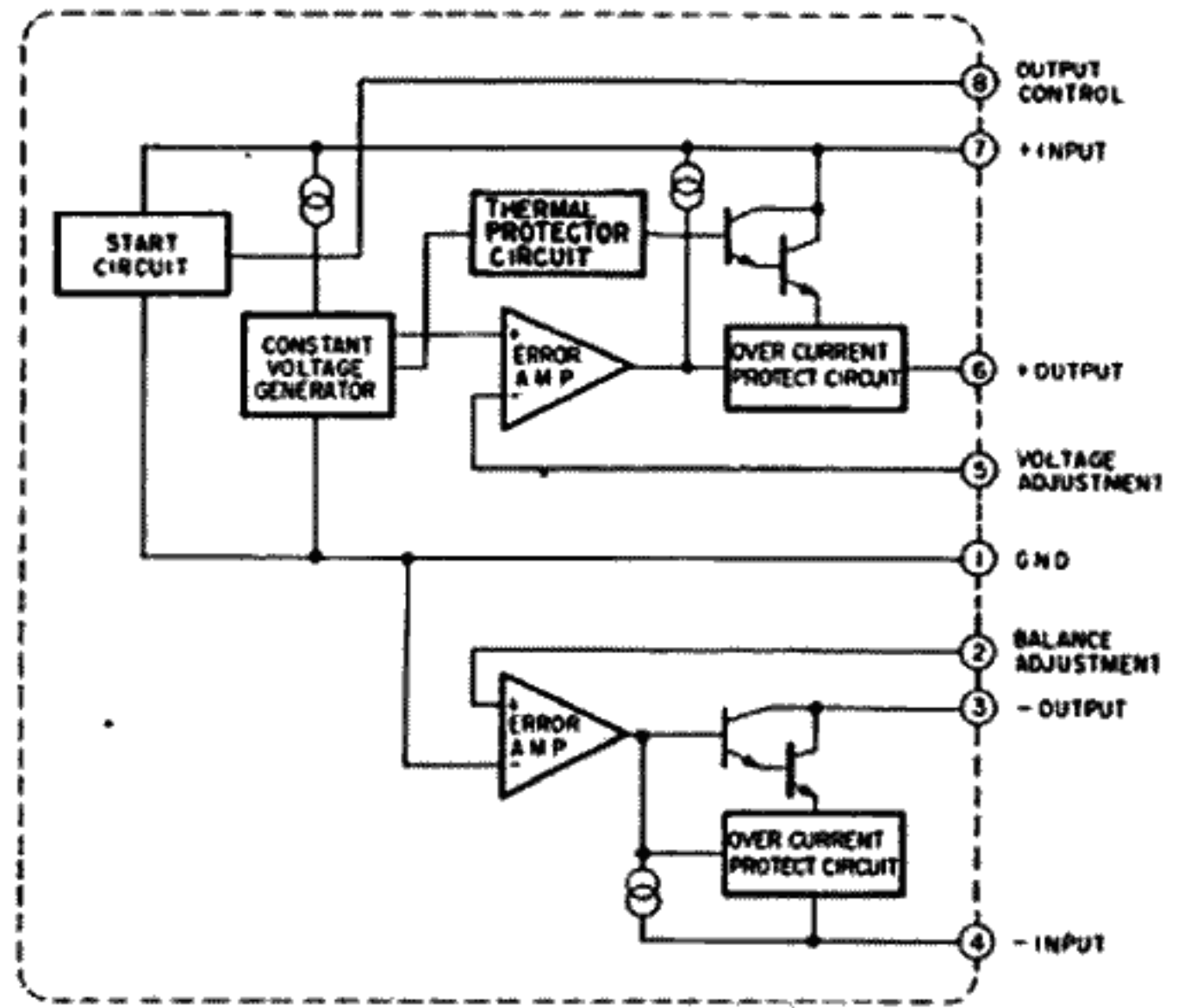
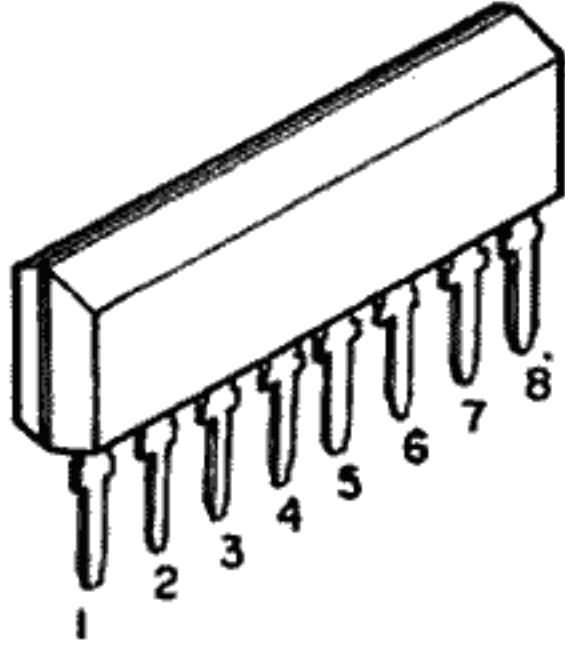

2SD592 : Q193

2SB621 : Q191, 192



2SC1815 : Q251, 253, 255

2SA1015 : Q252, 254, 256

2SC2878 : Q317, 318, 401, 402



2SK170 : Q301, 302, 303, 304



2SK389 : Q501, 502

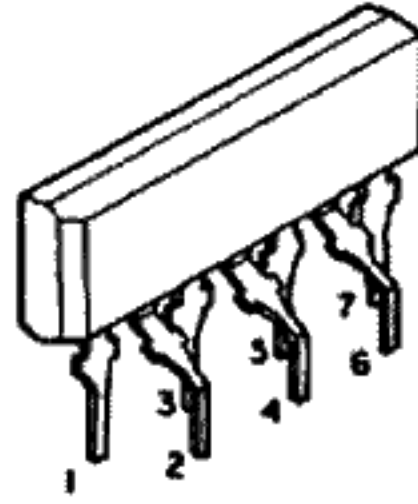

- 1. Drain 1
- 2. Gate 1
- 3. Source 1
- 4. Sub-straight
- 5. Source 2
- 6. Gate 2
- 7. Drain 2

2SC3467 : Q515, 516, 517, 518, 519, 520

2SA1370 : Q513, 514, 521, 522



2SD600K : Q527, 528

2SB631K : Q543, 544

2SC1953 : Q523, 524



2SA1302 : Q533, 534, 535, 536, 545, 546

2SC3281 : Q529, 530, 537, 538, 539, 540

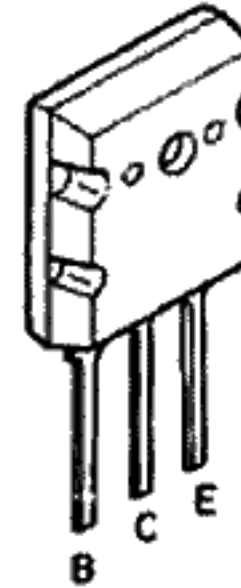

2SC3907 : Q547, 548

2SA1516 : Q531, 532



2SD1913 : Q752

2SB1274 : Q751

